

HD

COMPREHENSIVE EXAM - Sept '96

CLASSICAL ELECTRODYNAMICS

(Answer all 3 questions)

1. The magnetic field of the earth is approximately that of a magnetic dipole. Calculate the dipole moment  $\mathbf{m}$  using the fact that the horizontal component of the Earth's field at the surface is approximately 0.23 gauss at a latitude of  $40^\circ$ . If this moment were to be produced by a circular loop of radius equal to one-third the Earth's radius, what current (in amperes) would be necessary? (assume the geographic pole and the magnetic poles overlap)  $R_{\text{earth}}=6400 \text{ Km}$

(20points)

2. A Rogowski coil is a uniform toroidal winding (the toroid is of arbitrary shape, not necessarily a square or a circle -see figure). The crosssectional area of each loop of the winding is 'S'. There are 'n' turns per unit length. If a time dependent current  $I(t)$  passes anywhere and in any direction through the opening of the toroid, show that the EMF induced in the coil is:

$$\mathcal{E}(t) = \frac{4\pi}{c^2} nS \frac{dI}{dt}$$

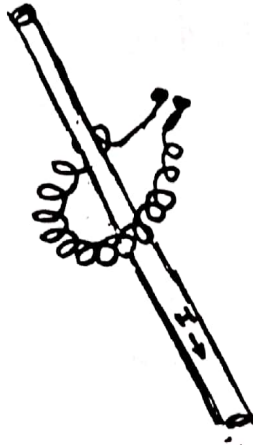

Note: No points for doing special cases of toroid or current

(20 points)

3. A linear dipole antenna of total length ' $\lambda/2$ ' is hooked up to a AC transmitter.

- (a) What is the current in the antenna
- (b) Find the vector potential in the far-field due to the oscillating current
- (c) Find the magnetic field due to the antenna

- (d) Find the corresponding electric field
- (e) If 'N' such linear antenna's are spaced ' $\lambda/2$ ' apart in a straight line and driven in phase. find the total electric field radiated by the array.
- (f) Find the corresponding time averaged Poynting vector
- (g) Find and plot the average power radiated per sec per unit solid angle.

(60 points)

1. a) A particle subjected to a harmonic potential is described, at  $t=0$ , by the wave function

$$\psi(x,0) = \delta(x) .$$

Determine  $\psi(x,t)$  for arbitrary  $t$ . Leave your answer in the form of a series (Hint: to determine the Hermite polynomials you may use the relation:  $e^{-s^2+2sx} = \sum_{n=0}^{\infty} \frac{H_n(x)s^n}{n!}$ ).

- b) Show, by calculating  $[[H, x], x]$  that  $\sum_n | \langle n' | x | n' \rangle |^2 (E_{n'} - E_{n''}) = \frac{\hbar^2}{m}$ , where  $H = \frac{p^2}{2m} + \frac{kx^2}{2}$ .

2. A particle in the ground state of a three dimensional square well of depth,  $-V_0$ , and range,  $R$ , is subjected to a potential

$$H(t) = \begin{cases} g e^{-\alpha r} e^{-i\omega t} & t > 0 \\ 0 & t < 0 \end{cases} .$$

If the particle is ionized, use Fermi's golden rule to determine the transition probability,  $W_{fi}$ , to a group of free particle states. For integration purposes ignore the inside ( $r < R$ ) wave function and assume  $R=0$  in the integration limits.

3. a) Determine the scattering amplitude  $f_B(\theta)$ , in first Born approximation, for the potential

$$V(r) = \frac{g}{r^2 + a^2} .$$

- b) Also obtain  $f_B(\theta)$  for a Yukawa potential  $V(r) = \frac{ge^{-\mu r}}{r}$ .

c) Compare (a) and (b) near  $\theta=0$  and explain why they behave drastically differently.

4. Obtain a limit on the lowest energy eigenvalue for a potential  $-\lambda e^{-\beta r}$  using the variational method. Take the trial wavefunction as  $e^{-\alpha r}$ . Also assume  $\frac{\hbar^2 \beta^2}{m\lambda} = \frac{3}{4}$ .

1. a) A particle subjected to a harmonic potential is described, at  $t=0$ , by the wave function

$$\psi(x,0) = \delta(x) .$$

Determine  $\psi(x,t)$  for arbitrary  $t$ . Leave your answer in the form of a series (Hint: to determine the Hermite polynomials you may use the relation:  $e^{-s^2+2sx} = \sum_{n=0}^{\infty} \frac{H_n(x)s^n}{n!}$ ).

- b) Show, by calculating  $[[H, x], x]$  that  $\sum_{n'} |\langle n'' | x | n' \rangle|^2 (E_{n'} - E_{n''}) = \frac{\hbar^2}{m}$ , where  $H = \frac{p^2}{2m} + \frac{kx^2}{2}$ .

2. A particle in the ground state of a three dimensional square well of depth,  $-V_0$ , and range,  $R$ , is subjected to a potential

$$H'(t) = \begin{cases} ge^{-\alpha r} e^{-i\omega t} & t > 0 \\ 0 & t < 0 \end{cases}$$

If the particle is ionized, use Fermi's golden rule to determine the transition probability,  $W_{fi}$ , to a group of free particle states. For integration purposes ignore the inside ( $r < R$ ) wave function and assume  $R=0$  in the integration limits.

3. a) Determine the scattering amplitude  $f_B(\theta)$ , in first Born approximation, for the potential

$$V(r) = \frac{g}{r^2 + a^2}$$

- b) Also obtain  $f_B(\theta)$  for a Yukawa potential  $V(r) = \frac{ge^{-\mu r}}{r}$ .

c) Compare (a) and (b) near  $\theta=0$  and explain why they behave drastically differently.

4. Obtain a limit on the lowest energy eigenvalue for a potential  $-\lambda e^{-\beta r}$  using the variational method. Take the trial wavefunction as  $e^{-\alpha r}$ . Also assume  $\frac{\hbar^2 \beta^2}{m\lambda} = \frac{3}{4}$ .

The following may be useful:

Stirling's Law:  $\ln N! \sim N \ln N - N$

$$\int_{-\infty}^{\infty} e^{-ax^2} dx = \left(\frac{\pi}{a}\right)^{1/2}, \quad \int_0^{\infty} x^2 e^{-ax^2} dx = \frac{\sqrt{\pi}}{4} a^{-3/2}, \quad \int_0^{\infty} x e^{-ax} dx = \frac{1}{a^2}$$

Gas constant  $R=2 \text{ cal/mol}\cdot\text{K}$

1 atmosphere =  $0.1 \text{ J/cm}^3$

1 cal = 4.2 J

1.

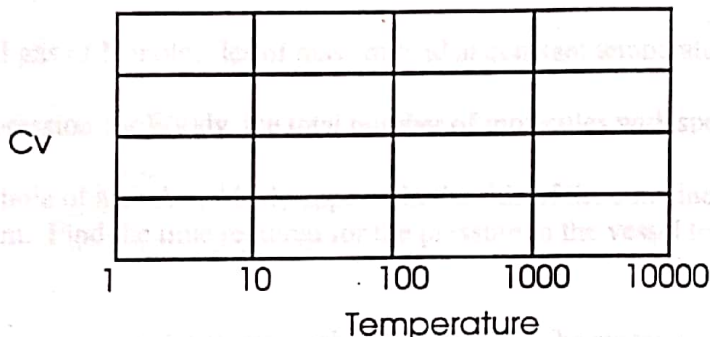

- Sketch the molar specific heat at constant volume vs temperature for  $N_2$  gas (an ideal diatomic gas) over the temperature range shown above. Give brief physical arguments for any features. You don't have to consider excited electronic states or dissociation.
- A liter of  $N_2$  gas at atmospheric pressure and  $0^\circ\text{C}$  in a rigid cylinder is raised to  $100^\circ\text{C}$  by placing it in contact with an infinite reservoir at  $100^\circ\text{C}$ . What are the changes in entropy of the  $N_2$  and the universe in  $\text{J/K}$ ?
- Assuming that one wall of the cylinder is allowed to act like a piston, describe a means of raising the gas temperature to  $100^\circ\text{C}$  (with the final volume of 1 liter) such that the entropy change  $\Delta S=0$  for the universe.

2. The following data apply to the triple point of water:

Temp=0.01°C,  
P=0.0060 atm,  
specific volume of solid=1.0907 cm<sup>3</sup>/g,  
specific volume of liquid=1.0001 cm<sup>3</sup>/g,  
heat of fusion=80 cal/g,  
heat of vaporization=596 cal/g.

Sketch a P-T diagram for water which need not be to scale, but which should be qualitatively correct. Consider what happens when the pressure is reduced slowly from some high value upon an amount of pure water enclosed in a cylinder and maintained at the temperature -1°C. Two phase changes will occur. Describe what these phase changes are and calculate the pressures at which they occur.

3. Consider an ideal gas of N molecules of mass m held at constant temperature T in a container of volume V.
- Derive an expression for  $F(v)dv$ , the total number of molecules with speeds between v and v+dv.
  - A very small hole of area A suddenly appears in the side of the container and the gas leaks out into a vacuum. Find the time required for the pressure in the vessel to drop to 1/e of its original value.
4. Consider a sample of N magnetic atoms, each with spin 1/2. The system is ferromagnetic at very low temperatures; thus as T approaches 0K all the spins are aligned. At sufficiently high temperatures, the spins are randomly oriented. Neglect all other degrees of freedom but the spin orientation.
- Define the entropy of the system in statistical terms.
  - Define the entropy of the system in terms of the specific heat and spin temperature.
  - Show that the specific heat C(T) must satisfy the equation:

$$\int_0^{\infty} \frac{C(T)dT}{T} = k_B N \ln(2)$$

irrespective of the details of the interactions bringing about ferromagnetic behavior or the detailed dependence of C(T).

5. Consider a **2-dimensional** Fermi gas of N, non-interacting electrons (a thin sheet of metal) of mass m, confined to a sheet of very large area A, ie., surface density= $n_s=N_s/A$ .
- What is the number of states with momentum vector amplitude between k and k+dk?
  - What is the number of states with energy between E and E+dE?
  - What's the Fermi Energy of this system at T=0K.
  - Find the relation between the mean surface pressure <p> vs surface area A, at T=0K.

# Comprehensive Exam: Classical Mechanics

September 24, 1996

There are 5 problems. Problems 1, 2, 3, and 4 are worth 10 points. Problem 5 is worth 20 points.

*Problem 1* - A point mass  $m$  lies on the perpendicular line through the center of a uniform thin circular disk of planar density  $\sigma$  and radius  $R$ . The mass is at a distance  $d$  from the center. Find the gravitational force between the plate and the mass  $m$ .

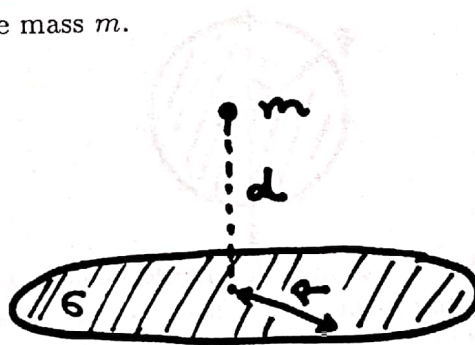

*Problem 2* - A bead of mass  $m$  slides without friction under the influence of gravity on a wire which is parametrically given by:  $x = R(2\theta - \sin(2\theta))$  and  $y = R(1 + \cos(2\theta))$  where  $0 \leq \theta \leq \pi$ . The acceleration of gravity is  $g$  and points downwards in the  $y$  direction. Using the Lagrangian formalism calculate the equation of motion for the bead. Show that the bead undergoes a harmonic motion and calculate its frequency of vibration. (HINT: find the equation of motion in terms of the angle  $\theta$  and make the substitution  $u = \cos \theta$  and calculate the equation of motion for  $u$ )

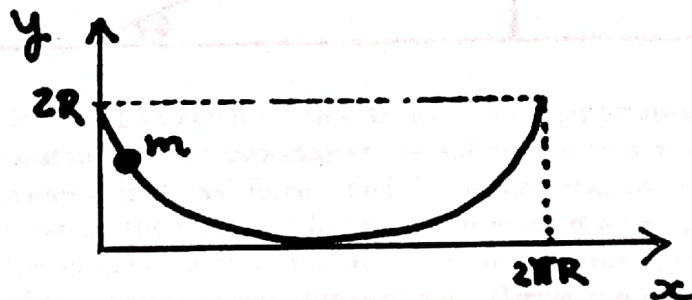

*Problem 3* - A uniform circular disc is spinning with an angular velocity  $\Omega$  about an axis through its center and on its plane (see figure). A point  $P$  on its rim is suddenly fixed at some time  $t = 0$ . If the disc has radius  $R$  and mass  $m$  and the point  $P$  makes an angle  $\theta$  with the diameter calculate the subsequent velocity of the center of the disc immediately after the impact.



*Problem 4* - A cylinder of mass  $M$  and radius  $R$  falls with velocity  $V$  and makes an inelastic collision with an inclined plane of mass  $m$  and angle  $\theta$  (see figure). The plane is free to move on a horizontal surface. Assume that the cylinder does not bounce out of the plane (the collision is inelastic) and it rolls without slipping after the collision. Calculate the vertical velocity of the center of the cylinder immediately after the impact.

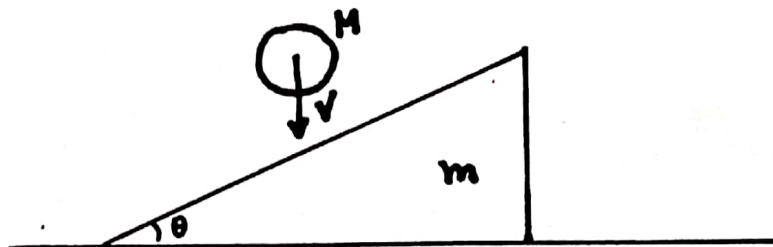

*Problem 5* - Two equal masses  $M$  are connected by springs having equal spring constant  $k$ . The two masses are submerged in a vessel with a liquid that provides a frictional force which is proportional to the velocity of the masses (that is, the frictional force can be written as  $\vec{F}_{fric} = -2\gamma\vec{v}$ ). The ends of the springs are fixed and attached to the walls of the vessel and the motion of the masses is one dimensional. Derive the equations of motion



for the two masses. Find the frequencies of oscillation. Make a picture of the normal modes of oscillation for this system. Now we do the following experiment: we increase the temperature of the vessel in such a way that the viscosity of the liquid changes. Assume that the viscosity decreases linearly with temperature. Discuss how many modes are going to be overdamped and how many are going to be underdamped as a function of temperature in this experiment. Assume that at zero temperature we have  $\gamma \gg 3k$ .

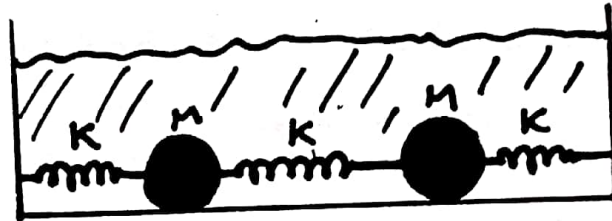

1. a) Calculate the following integral using contour integration methods for functions with branch cuts (e.g. integration of the type  $\int_0^{\infty} dx x^{\alpha} f(x)$  with non-integral  $\alpha$ )

$$\int_0^{\infty} \frac{dx}{\sqrt{x}(x-1-i\epsilon)}$$

- b) Do the same integral as (a) above but after first making a change of variables  $\sqrt{x} = u$  and then using Cauchy's integral theorem.
2. Determine the Green's function using Fourier Transforms for the following equation:

$$\nabla^2 u(\mathbf{r}) + k_0^2 u(\mathbf{r}) = f(\mathbf{r}) .$$

Obtain  $u(\mathbf{r})$  using the Green's function technique with  $u(\mathbf{r})$  satisfying outgoing wave boundary conditions.

3. a) Solve the following differential equation using the Laplace transform technique

$$\frac{\partial f(x,t)}{\partial t} - \frac{\partial^2 f(x,t)}{\partial x^2} = 0 ; 0 < x < l; t > 0$$

with the boundary conditions:  $f(x,0) = 0 = f(0,t); f(l,t) = 1 .$

- b) Verify that your solution satisfies the above boundary conditions.
4. a) Show that the following three matrices do not form a group under multiplication. Explain why.

$$E = \begin{pmatrix} 1 & 0 \\ 0 & 1 \end{pmatrix}, A_1 = \begin{pmatrix} \omega & 0 \\ 0 & \omega^2 \end{pmatrix}, B_1 = \begin{pmatrix} 0 & 1 \\ 1 & 0 \end{pmatrix}; \omega = \exp(2\pi i / 3)$$

Add appropriate numbers of 2X2 matrices to complete a group of smallest order possible.

- b) Write the corresponding multiplication table and indicate if the group is abelian or not. Also determine the (i) subgroups, (ii) invariant subgroups, and (iii) factor groups.

# Comprehensive Exam: Quantum Mechanics

March 28, 9-11 A.M.

Do any four problems.

1. Consider a particle moving in three dimensions in the presence of an *attractive* spherically symmetric potential,

$$V(r) = A\delta(r - a); \quad A < 0.$$

- (a) Restrict yourself to the zero angular momentum case and find a transcendental equation that determines the negative energy eigenvalues. Are there solutions for all values of  $A$ ?

- (b) For non-zero angular momentum find the zero energy eigenfunctions.

Hint: Try solutions of the form  $r^\nu$  for the radial wave-functions in part b.

2. Consider a particle moving in three dimensions in the presence of a *repulsive* spherically symmetric potential,

$$V(r) = A\delta(r - a); \quad A > 0$$

(note that now the potential is repulsive).

- (a) Find the Born approximation to the differential scattering cross section.

- (b) Find the  $\ell = 0$  phase shift and, neglecting the contributions from  $\ell \geq 1$ , find an approximation to the differential scattering cross section.

- (c) When are the above approximations to the scattering cross section expected to be valid?

The relevant spherical Bessel functions and spherical harmonics are

$$j_0(z) = \frac{\sin z}{z}; \quad n_0(z) = -\frac{\cos z}{z}; \quad Y_0^0(\theta, \phi) = \frac{1}{\sqrt{4\pi}}$$

3. Consider a particle of mass  $\mu$  moving in a time independent magnetic field whose vector potential is

$$A = (Bx) \hat{y}$$

where  $\hat{y}$  is the unit vector in the  $y$  direction and  $B$  is a constant. The scalar potential vanishes.

(a) Find the Hamiltonian and two operators that commute with it.

(b) Use the above results to find the eigen-energies of the system.

Hint: The energies of a harmonic oscillator of frequency  $\omega$  are  $\frac{1}{2}\hbar\omega(2n+1)$ ,  $n = 0, 1, 2, \dots$

4. A hydrogen atom is placed in a time-dependent homogeneous electric field given by

$$E(t) = \frac{A\tau}{t^2 + \tau^2} \hat{z}$$

where  $\hat{z}$  is the unit vector in the  $z$ -direction,  $A$  is a constant and  $\tau$  is a characteristic time constant. If at  $t = -\infty$  the atom is in its ground state, calculate the probability  $P$  that at  $t = +\infty$  it has made a transition to the first excited state. Show that if  $\tau$  is very large the probability is very small and estimate the value of  $\tau$  for which  $P \ll 1$ .

You may use the following spherical harmonics and hydrogen radial wavefunctions

$$(\psi_{nlm} = R_{nl}Y_{lm})$$

$$Y_{00} = \frac{1}{\sqrt{4\pi}}$$

$$Y_{10} = \sqrt{\frac{3}{4\pi}} \cos \theta$$

$$R_{10} = \left(\frac{1}{a_0}\right)^{3/2} 2e^{-r/a_0}$$

$$R_{21} = \left(\frac{1}{2a_0}\right)^{3/2} \frac{r}{a_0\sqrt{3}} e^{-r/2a_0}$$

The following integral may also be required

$$\int_0^{\infty} e^{-\alpha x} dx = \alpha^{-1}$$

5. A simple harmonic oscillator in one dimension with unperturbed Hamiltonian

$$H_0 = \frac{p^2}{2m} + \frac{1}{2}m\omega^2 x^2$$

is subjected to a perturbation

$$\lambda H_1 = \frac{1}{2}\lambda m\omega^2 x^2$$

where  $\lambda$  is a dimensionless constant such that  $\lambda \ll 1$ .

- (a) Use *perturbation theory* to calculate the energy levels of the perturbed oscillator up to order  $\lambda^2$ .
- (b) Find an expression for the ground state eigenket in terms of the unperturbed eigenkets up to  $O(\lambda)$ .
- (c) Calculate the energy levels of the perturbed oscillator *directly* and compare your result with that obtained in part (a).

## Comprehensive Exam: Quantum Mechanics

There are 3 problems which are divided into sections. Problems 1 and 2 are worth 20 points each. Problem 3 is worth 60 points.

*Problem 1* - A particle is moving in a infinitely deep well which is given by:  $V(x) = 0$  if  $-a < x < a$  and  $V(x) = \infty$  if  $|x| > a$ .

A) Solve the Schrödinger equation for this potential. Find the spectrum and the *normalized* wave functions. Draw a figure of the ground state and the first two excited states and give their energy.

B) Suppose another potential is added to the one above. This potential is given by  $V_{extra}(x) = V_0\delta(x)$  where  $\delta(x)$  is a Dirac delta function ( $V_0 > 0$ ). Write down the Schrödinger equation and by using the appropriate boundary conditions at  $x = 0$  and find the eigenfunctions of the problem. Compare *qualitatively* the spectrum of this problem with the one of part A). Show that we can recover the spectrum in A) if you set  $V_0 \rightarrow 0$ . Discuss what happens when  $V_0 \rightarrow \infty$ . Give a *qualitative* discussion of what happens when  $V_0$  becomes negative. **Hint:** Integrate the Schrödinger equation from  $-\epsilon$  to  $\epsilon$  and make  $\epsilon \rightarrow 0$  in order to obtain the boundary condition at  $x = 0$ .

*Problem 2* - A non-spherical charged atom has an electric dipole moment that oscillates. This atom is in the ground state when an external homogeneous electric field is applied. The potential created by the external field is:  $V_{ext}(x) = -Fx$ . Assume that the dipole can be described in terms of an one-dimensional harmonic oscillator with frequency  $\omega_0$  and effective mass  $m$ . The field is applied in the direction of motion. Determine the probability that the oscillator remains in the ground state after  $F$  is applied. **Hint:** Make a drawing of the total potential as a function of  $x$  for various values of  $F$ . The ground state wave function of the harmonic oscillator is:

$$\Psi_0(x) = \left(\frac{m\omega_0}{\pi\hbar}\right)^{1/4} e^{-m\omega_0 x^2/(2\hbar)}$$

and you will probably need to use the integral:

$$\int_{-\infty}^{+\infty} dx e^{-ax^2+bx} = \sqrt{\frac{\pi}{a}} e^{b^2/(4a)}.$$

*Problem 3* - A molecule is made out of two atoms with spin 1/2. A) If the two atoms do not interact with each other what are the possible configurations for this problem in the basis of the operator  $S^z$ ? Use a notation

such that the eigenstates of  $S^z$  are  $|\uparrow\rangle$  represents an up spin and  $|\downarrow\rangle$  represents a down spin.

B) Consider now the case where the spins interact antiferromagnetically, that is, the Hamiltonian of the system is given by

$$H_0 = \frac{2\epsilon_0}{\hbar^2} S_1^z S_2^z \quad (1)$$

where  $S_i^z$  with  $i = 1, 2$  represents each one of the atoms and  $\epsilon_0$  is the energy scale. What are the eigenstates and eigenenergies of the system? Are there any degenerate states?

C) A very weak magnetic field is applied to the atom 2. The interaction between the magnetic field and the atom can be represented by the perturbation

$$V_1 = -\frac{2\Delta}{\hbar} S_2^z. \quad (2)$$

What are the energies of the states in the presence of  $V_1$ ? Are the states degenerate? Is there a value of  $\Delta$  for which the states become degenerate? What is the lowest energy state?

D) Consider now the possibility that one of the spins can tunnel from one configuration to another. The simplest way to describe the tunneling is via the Hamiltonian

$$H_t = \frac{2\lambda}{\hbar} S_1^x \quad (3)$$

where  $\lambda$  is the tunneling energy and  $S_1^x$  is the  $x$ -component of the spin 1. Assume now that  $\Delta, \lambda \gg \epsilon_0$  (that is, you can set  $\epsilon_0 = 0$  and the Hamiltonian becomes  $H = V_1 + H_t$ ). Assume that  $H_t$  is a perturbation to  $V_1$ . Calculate in the *leading* order (non-zero!) in perturbation theory the shift in the energies and eigenstates of  $V_1$ . Solve the problem exactly and compare with the results of perturbation theory. What do you conclude?

E) Assume that (3) is a perturbation to (1) and disregard  $V_1$ . Calculate in the *leading* order (non-zero!) in perturbation theory the shift in energy and eigenstates of (1). Solve the problem  $H = H_0 + H_t$  exactly and compare with the result of the perturbation theory.

# Comprehensive Exam: Quantum Mechanics

Sept 21, 9:15 A.M.-11:15 A.M.

Do 4 problems.

1. The time-independent Dirac Hamiltonian for a free electron is given by  $H = c\vec{\alpha} \cdot \vec{p} + mc^2\beta$ , where  $\vec{\alpha}$  and  $\beta$  are the  $4 \times 4$  Dirac matrices,

$$\vec{\alpha} = \begin{pmatrix} 0 & \vec{\sigma} \\ \vec{\sigma} & 0 \end{pmatrix}, \quad \beta = \begin{pmatrix} 1 & 0 \\ 0 & -1 \end{pmatrix}.$$

- (a) Calculate the commutator  $[H, L_z]$  where  $L_z$  is the orbital angular momentum of the electron along the  $z$  direction.
- (b) Calculate the commutator  $[H, \Sigma_z]$ , where

$$\Sigma_z = \begin{pmatrix} \sigma_z & 0 \\ 0 & \sigma_z \end{pmatrix}.$$

- (c) From the above results, determine the linear combination of  $L_z$  and  $\Sigma_z$  which commutes with  $H$  and interpret your result in terms of a specific conservation law.

Note:  $\vec{\sigma}$  are the usual  $2 \times 2$  Pauli spin matrices.

2. A particle of mass  $m$  is bound by the spherically symmetric potential

$$V(r) = -\frac{4\hbar^2}{3ma^2} \exp\left(-\frac{r}{a}\right).$$

Use the variation method with the trial function  $e^{-\alpha r}$  to get a good limit on the lowest energy eigenvalue.

3. The Born scattering amplitude is given by

$$f_B(\vec{k}_\beta, \vec{k}_\alpha) = -\frac{m}{2\pi\hbar^2} \int V(\vec{r}) \exp(i\vec{q} \cdot \vec{r}) d^3r, \quad \vec{q} = \vec{k}_\alpha - \vec{k}_\beta,$$



1. a) A particle subjected to a harmonic potential is described, at  $t=0$ , by the wave function

$$\psi(x,0) = \delta(x) .$$

Determine  $\psi(x,t)$  for arbitrary  $t$ . Leave your answer in the form of a series (Hint: to determine the Hermite polynomials you may use the relation:  $e^{-s^2+2sx} = \sum_{n=0}^{\infty} \frac{H_n(x)s^n}{n!}$ ).

- b) Show, by calculating  $[[H, x], x]$  that  $\sum_n |<n''|x|n'>|^2 (E_{n'} - E_{n''}) = \frac{\hbar^2}{m}$ , where  $H = \frac{p^2}{2m} + \frac{kx^2}{2}$ .

2. A particle in the ground state of a three dimensional square well of depth,  $-V_0$ , and range,  $R$ , is subjected to a potential

$$H(t) = \begin{cases} ge^{-\alpha r} e^{-i\omega t} & t > 0 \\ = 0 & t < 0 \end{cases}$$

If the particle is ionized, use Fermi's golden rule to determine the transition probability,  $W_{fi}$ , to a group of free particle states. For integration purposes ignore the inside ( $r < R$ ) wave function and assume  $R=0$  in the integration limits.

3. a) Determine the scattering amplitude  $f_B(\theta)$ , in first Born approximation, for the potential

$$V(r) = \frac{g}{r^2 + a^2} .$$

- b) Also obtain  $f_B(\theta)$  for a Yukawa potential  $V(r) = \frac{ge^{-\mu r}}{r}$ .

c) Compare (a) and (b) near  $\theta=0$  and explain why they behave drastically differently.

4. Obtain a limit on the lowest energy eigenvalue for a potential  $-\lambda e^{-\beta r}$  using the variational method. Take the trial wavefunction as  $e^{-\alpha r}$ . Also assume  $\frac{\hbar^2 \beta^2}{m\lambda} = \frac{3}{4}$ .

where  $\vec{k}_\alpha$  and  $\vec{k}_\beta$  denote the incoming and outgoing momenta respectively.

- (a) Simplify this in the case of a spherically symmetric  $V$  and obtain the differential scattering cross section for the screened Coulomb potential

$$V(r) = -(Ze^2/r)e^{-r/a}.$$

- (b) State briefly when is the Born approximation expected to be accurate.

4. A particle of mass  $m$  moves in one dimension according to a time-independent potential satisfying  $V(x) = V(-x)$ .

(a) Let the state function be written as:  $\psi(x, t) = U(t, t_0)\psi(x, t_0)$ . Using the time-dependent Schrödinger equation, derive the general expression for the evolution operator  $U(t, t_0)$ . If  $\psi(x, t_0)$  is an odd function of  $x$ , determine the parity of  $\psi(x, t)$  at any time  $t > t_0$ .

(b) Let  $\psi(x, t_0) = \delta(x)$  and  $V(x) = 0$ . Calculate  $\psi(x, t)$  in closed form using the results from (a).

5. Consider a one-dimensional harmonic oscillator with the Hamiltonian

$$H = \frac{p^2}{2m} + \frac{m\omega_0^2 x^2}{2}.$$

(a) Evaluate the commutator  $[a, a^\dagger]$ , where

$$a = (2m\hbar\omega_0)^{-\frac{1}{2}}(p - im\omega_0 x).$$

(b) Denote the ground state by  $|0\rangle$  (which is annihilated by  $a$ ) and let

$$|\beta\rangle = \sum_{n=0}^{\infty} \frac{\beta^n}{n!} (a^\dagger)^n |0\rangle,$$

where  $\beta$  is an arbitrary complex number. Using the results from (a) evaluate  $a|\beta\rangle$  and also

$$\frac{\langle\beta|H|\beta\rangle}{\langle\beta|\beta\rangle}.$$

## Comprehensive Exam: Quantum Mechanics

Monday, March 25: 9:15 - 11:15am

I. A particle trapped within two infinite walls at  $x = \pm a$  has a 50-50 probability of being in the ground state and the first excited state. Obtain its wave function at  $t=0$  and  $t>0$ .

II. (a) Determine the scattering amplitude,  $f_b(\theta)$ , in the first Born approximation in the forward ( $\theta=0$ ) direction for the following scattering potential

$$V(r) = \begin{cases} V_0 & r \leq a \\ 0 & r > a \end{cases}$$

(b) If  $V_0 = \infty$  in the above problem, determine the S-wave phase shift, and the S-wave cross-section.

III. A one-electron atom is bombarded with sticky nucleons for a time  $T$ .

(a) Assume first that the incoming nucleons are neutral so that the main effect is an increase in the nuclear mass:  $M = M_0 + \mu(t)$ ; assume  $M_0 \gg m_{\text{electron}}$ .

Suppose the electron is initially in the  $1S$  state, working to the lowest non-trivial order in  $\mu(t)$ . determine the transition probability to the  $|n, \ell, m\rangle$  state (you are *not* to perform the integrals explicitly); for which values of  $\ell$  and  $m$  is this zero? Evaluate explicitly the transition probability to the  $|2, 0, 0\rangle$  state.

(b) Suppose now that the impinging nucleons are charged but as many positive as negative stick to the atom's nucleus. Even though the charge does not change, both the mass and the electric dipole of the nucleus change with time.

Find the transition probability (with both the effects from the dipole and mass changes) from the  $|1, 0, 0\rangle$  to the  $|n, \ell, m\rangle$  state in terms of the wave functions; determine the corresponding selection rules and evaluate the probability for the transition to the  $|2, 0, 0\rangle$  and the  $|2, 1, 0\rangle$  states.

Some expressions which are of use:

$$\langle r, \theta, \phi | 1, 0, 0 \rangle = \sqrt{\frac{Z^3}{\pi a^3}} e^{-Zr/a}$$

$$\langle r, \theta, \phi | 2, 0, 0 \rangle = \sqrt{\frac{Z^3}{8\pi a^3}} \left(1 - \frac{Zr}{2a}\right) e^{-Zr/(2a)}$$

$$\langle r, \theta, \phi | 2, 1, 0 \rangle = \sqrt{\frac{Z^5}{32\pi a^5}} r e^{-Zr/(2a)}$$

where  $a$  denotes the Bohr radius and  $Z$  the charge of the nucleus.

## Comprehensive Exam: Quantum Mechanics

Monday, March 25: 9:15 - 11:15am

*continued, page 2*

IV. (a) For the Schrodinger equation

$$\left( \frac{\hbar^2 \vec{\nabla}^2}{2m} + i\hbar \frac{\partial}{\partial t} \right) \psi(\mathbf{x}) = V(\mathbf{x}) \psi(\mathbf{x}); \quad \mathbf{x} = (\mathbf{r}, t)$$

express  $\psi(\mathbf{x})$  in the integral representation

$$\psi(\mathbf{x}) = \psi_0(\mathbf{x}) + \int d^4x' G_0(\mathbf{x}, \mathbf{x}') V(\mathbf{x}') \psi(\mathbf{x}')$$

and obtain the Green's function,  $G_0(\mathbf{x}, \mathbf{x}')$ , using causality, where  $\psi_0$  is the solution to the homogeneous equation. Use the Fourier-transform technique.

(b) For a free particle Dirac Hamiltonian use the Heisenberg representation for the operator  $\mathbf{x}$  to show that

$$\vec{\alpha} = \frac{1}{c} \frac{d\mathbf{x}}{dt}$$

where  $\vec{\alpha}$  is a Dirac matrix.

Comprehensive Exam: Quantum Mechanics  
Monday, September 18, 1995, 9:15–11:15 AM

Do 4 out of 5 problems.

1. A particle of mass  $m$  moves in a three-dimensional potential

$$V(r) = \begin{cases} -V_0, & r < a, \\ 0, & r > a, \end{cases}$$

with  $V_0 > 0$ .

(a) Use a dimensional argument to estimate the smallest value of  $V_0$  such that there is a bound state of zero energy and zero angular momentum.

(b) Now find this value of  $V_0$  exactly. *Hint:* work with the function  $r\psi(r)$  rather than the Schrödinger wave function  $\psi(r)$ .

2. (a) For a Dirac particle show that

$$[\mathbf{L}, \boldsymbol{\alpha} \cdot \mathbf{p}] = i\hbar(\boldsymbol{\alpha} \times \mathbf{p}).$$

(b) Consider a Dirac particle in a central potential, and indicate which of the following operators commutes with the Hamiltonian:  $L_z$ ,  $S_z$ ,  $J_z$ ,  $(\mathbf{L})^2$ ,  $(\mathbf{S})^2$ ,  $(\mathbf{J})^2$ . State your answers *without* any explicit proof. What are the physical reasons for these answers?

3. The Hamiltonian

$$H = A(\sigma_z^{(1)} + \sigma_z^{(2)}) + B\boldsymbol{\sigma}^{(1)} \cdot \boldsymbol{\sigma}^{(2)},$$

where the  $\sigma$ s are Pauli spin matrices, describes two spin one-half particles interacting with each other and with a magnetic field. The two particles are in distinct orbital states, so that there is no restriction on their spin states.

(a) Show that the eigenstates of  $H$  are also eigenstates of total spin operators  $S^2 = \frac{1}{4}|\boldsymbol{\sigma}^{(1)} + \boldsymbol{\sigma}^{(2)}|^2$  and  $S_z = \frac{1}{2}(\sigma_z^{(1)} + \sigma_z^{(2)})$ .

(b) Classify these eigenstates into singlet and triplet states, and find their energy eigenvalues.

4. A time-dependent perturbing term  $H'_{fi}(t)$  in the Hamiltonian of a system causes transitions from an initial eigenstate  $|i\rangle$  to a final eigenstate  $|f\rangle$  of the unperturbed Hamiltonian.

(a) Consider a perturbation given by

$$H'_{fi}(t) = \begin{cases} 0, & t < 0, \\ g_{fi} e^{-i\omega t}, & t > 0, \end{cases}$$

where  $g_{fi}$  is independent of time and  $\omega$  is real and positive. Determine to first order in time-dependent perturbation theory the transition probability  $|c_{fi}(t)|^2$ , and the transition probability per unit time  $\lambda_{fi}$  as  $t \rightarrow \infty$ .

(b) Repeat the calculation of Part (a) for

$$H'_{fi}(t) = \begin{cases} 0, & t < 0, \\ g_{fi} e^{-at} e^{-i\omega t}, & t > 0, \end{cases}$$

where  $a$  is real and positive.

(c) Suppose the transitions in Part (a) above occurred to a state in a continuum of free-particle states. Write down the probability per unit time (as  $t \rightarrow \infty$ ) of a transition into any member of a group of such states with energy  $E_f$ . Carefully define all symbols.

5. (a) Carefully enumerate the conditions which a scattering potential must satisfy if a phase shift  $\delta_\ell$  can be defined. Define the phase shift under these conditions, and make a *physical* argument for the behavior of  $\delta_\ell$  as the momentum  $k$  of the incident particle vanishes.

(b) Find the scattering amplitude in the first Born approximation for the potential

$$V(r) = -\frac{g}{r^2 + a^2},$$

where  $g$  and  $a$  are real and positive.

#### Useful Information

$$\nabla^2 \psi = \frac{1}{r^2} \frac{\partial}{\partial r} \left( r^2 \frac{\partial \psi}{\partial r} \right) \hat{r} + \frac{1}{r^2 \sin \theta} \frac{\partial}{\partial \theta} \left( \sin \theta \frac{\partial \psi}{\partial \theta} \right) \hat{\theta} + \frac{1}{r^2 \sin^2 \theta} \frac{\partial^2 \psi}{\partial \phi^2} \hat{\phi} \quad (\text{spherical coordinates})$$

# Physics Comprehensive Exam: Quantum Mechanics

March 27, 1995

9:15 – 11:15 am

Do 4 out of 5 problems.

(1) Let  $\psi$  be a bound-state solution of the three-dimensional Schrödinger equation with definite energy. Show that each component of  $\nabla\psi$  (the gradient of  $\psi$ ) is orthogonal to  $\psi$ .

Hint: Use the correspondence principle.

(2) Consider a one-dimensional  $\delta$ -function potential barrier  $V(x) = b\delta(x)$ . Obtain the transmission coefficient for a particle approaching from the left with energy  $E$ .

(3) Consider an arbitrary state (not necessarily an energy eigenstate) of the one-dimensional harmonic oscillator:  $H = p^2/2m + kx^2/2$ . Show that both  $\langle x^2 \rangle$  and  $\langle p^2 \rangle$  are periodic functions of time and obtain their corresponding frequencies.

Hint: Use  $dx/dt = -i\hbar^{-1}[x, H]$ , etc.

(4) Use the WKB method to estimate the number of bound states for a one-dimensional potential  $V(x) = -V_0 \exp(-|x|/a)$ , where  $mV_0a^2/\hbar^2 = 1$ .

(5) Consider a hydrogen atom in its ground state in the presence of a weak external uniform static electric field  $E$  along the  $z$ -direction. Use perturbation theory to find an upper bound on its electric polarizability.

Hint: The unperturbed energy eigenvalues are  $-e^2/2a_0n^2$ . The unperturbed ground-state wavefunction is  $(\pi a_0^3)^{-1/2} \exp(-r/a_0)$ . [ $a_0$  is the Bohr radius.] A useful integral is

$$\int_0^{\infty} r^n e^{-br} dr = \frac{n!}{b^{n+1}}. \quad (1)$$

HD

## Comprehensive Exam: Quantum Mechanics

Monday, March 25: 9:15 - 11:15am

I. A particle trapped within two infinite walls at  $x = \pm a$  has a 50-50 probability of being in the ground state and the first excited state. Obtain its wave function at  $t=0$  and  $t>0$ .

II. (a) Determine the scattering amplitude,  $f_b(\theta)$ , in the first Born approximation in the forward ( $\theta=0$ ) direction for the following scattering potential

$$V(r) = \begin{cases} V_0 & r \leq a \\ 0 & r > a \end{cases}$$

(b) If  $V_0 = \infty$  in the above problem, determine the S-wave phase shift, and the S-wave cross-section.

III. A one-electron atom is bombarded with sticky nucleons for a time  $T$ .

(a) Assume first that the incoming nucleons are neutral so that the main effect is an increase in the nuclear mass:  $M = M_0 + \mu(t)$ ; assume  $M_0 \gg m_{\text{electron}}$ .

Suppose the electron is initially in the 1S state, working to the lowest non-trivial order in  $\mu(t)$ . determine the transition probability to the  $|n, \ell, m\rangle$  state (you are *not* to perform the integrals explicitly); for which values of  $\ell$  and  $m$  is this zero? Evaluate explicitly the transition probability to the  $|2, 0, 0\rangle$  state.

(b) Suppose now that the impinging nucleons are charged but as many positive as negative stick to the atom's nucleus. Even though the charge does not change, both the mass and the electric dipole of the nucleus change with time.

Find the transition probability (with both the effects from the dipole and mass changes) from the  $|1, 0, 0\rangle$  to the  $|n, \ell, m\rangle$  state in terms of the wave functions; determine the corresponding selection rules and evaluate the probability for the transition to the  $|2, 0, 0\rangle$  and the  $|2, 1, 0\rangle$  states.

Some expressions which are of use:

$$\langle r, \theta, \phi | 1, 0, 0 \rangle = \sqrt{\frac{Z^3}{\pi a^3}} e^{-Zr/a}$$

$$\langle r, \theta, \phi | 2, 0, 0 \rangle = \sqrt{\frac{Z^3}{8\pi a^3}} \left(1 - \frac{Zr}{2a}\right) e^{-Zr/(2a)}$$

$$\langle r, \theta, \phi | 2, 1, 0 \rangle = \sqrt{\frac{Z^5}{32\pi a^5}} r e^{-Zr/(2a)}$$

where  $a$  denotes the Bohr radius and  $Z$  the charge of the nucleus.



# Comprehensive Exam: Quantum Mechanics

Monday, March 25: 9:15 - 11:15am

continued, page 2

Do any 3 of the following 4 questions.

IV. (a) For the Schrodinger equation

$$\left( \frac{\hbar^2 \vec{\nabla}^2}{2m} + i\hbar \frac{\partial}{\partial t} \right) \psi(\mathbf{x}) = V(\mathbf{x}) \psi(\mathbf{x}); \quad \mathbf{x} = (\vec{r}, t)$$

express  $\psi(\mathbf{x})$  in the integral representation

$$\psi(\mathbf{x}) = \psi_0(\mathbf{x}) + \int d^4x' G_0(\mathbf{x}, \mathbf{x}') V(\mathbf{x}') \psi(\mathbf{x}')$$

and obtain the Green's function,  $G_0(\mathbf{x}, \mathbf{x}')$ , using causality, where  $\psi_0$  is the solution to the homogeneous equation. Use the Fourier-transform technique.

(b) For a free particle Dirac Hamiltonian use the Heisenberg representation for the operator  $\mathbf{x}$  to show that

$$\vec{\alpha} = \frac{1}{c} \frac{d\mathbf{x}}{dt}$$

where  $\vec{\alpha}$  is a Dirac matrix.

## Comprehensive Exam: Nuclear Physics

Monday, March 25: 11:30am - 12:30pm

**Do any 3 of the following 4 questions:**

1. A relativistic particle of mass  $m$  and charge  $q$  circles another particle of mass  $M$  and charge  $Q$ . Suppose the orbit of  $m$  is a circle of radius  $R$ , and that  $M \gg m$ . Using Bohr's quantization condition find the quantum energy levels of this system.

Suppose now that  $q = Q$  and that the first two levels have energies  $E_1 = 3.097$  GeV,  $E_2 = 3.685$  GeV, determine  $q$ . (These values come from the  $J/\psi$  system; you are estimating the coupling strength for the strong interactions).

2. A  $D^{*+}$  meson is produced with a total energy (rest plus kinetic) of 8 GeV and decays by the channel  $D^{*+} \rightarrow K^- \pi^+ \pi^+$ . What are the minimum and maximum energies for the  $K^-$  daughter which are kinematically possible? Use  $M_{D^{*+}} = 2.01$  GeV,  $M_{K^-} = 0.49$  GeV and  $M_{\pi^+} = 0.14$  GeV.

3. A beam of neutrons of kinetic energy 0.29 eV, intensity  $10^5$  s $^{-1}$  traverses normally a foil of  $^{235}_{92}\text{U}$ , thickness  $10^{-1}$  kg m $^{-2}$ . Any neutron-nucleus collision can have one of three possible results:

- (1) elastic scattering of neutrons:  $\sigma_s = 2 \times 10^{-30}$  m $^2$ ,
- (2) capture of the neutron followed by the emission of a  $\gamma$ -ray by the nucleus:  $\sigma_c = 7 \times 10^{-27}$  m $^2$ ,
- (3) capture of the neutron followed by splitting of nucleus in two almost equal parts (fission):  $\sigma_f = 2 \times 10^{-26}$  m $^2$ .

Calculate:

- (a) the attenuation of the neutron beam by the foil;
- (b) the number of fission reactions occurring per second in the foil, caused by the incident beam;
- (c) the flux of elastically scattered neutrons at a point 10 m from the foil and out of the incident beam, assuming isotropic distribution of the scattered neutrons

4.  $^{40}_{20}\text{Ca}$  is the heaviest stable nucleus with  $Z = N$ . (It is doubly magic.) The neutron separation energy is 15.6 MeV. Estimate the proton separation energy, and compare your estimate with the empirical value of 8.3 MeV.

## Comprehensive Exam: Mathematical Methods

Tuesday, March 26: 9:15 - 11:15am

I. (a) Determine which of the following three functions are analytic

(i)  $z^2$                       (ii)  $z^*$                       (iii)  $2x + ixy^2$

(b) The following functions are singular. Explain the exact nature of their singularity, and, if poles exist, determine on which Riemann-sheet they lie

(i)  $\ln z$                       (ii)  $\frac{1}{\sqrt{z+i}}$                       (iii)  $\exp(z^2)$

(c) Use residues to evaluate the following integral

$$\int_0^{\infty} dx \frac{\cos x}{x^2 + 1}$$

II. A wire stretched tightly between fixed supports at  $x = 0$  and  $x = \pi$  is initially at rest until a gust of wind comes along. Assuming the wind can be modeled as a simple sinusoidal function of time with constant amplitude applied normally to the wire, determine the subsequent motion of the wire.

III. (a) Solve the boundary value problem for the temperature distribution in an infinite rod in the presence of a heat source,

$$U_{xx} = \frac{U}{a^2} - q(x, t), \quad -\infty < x < \infty, \quad t > 0$$

with the boundary conditions  $U(x, t) = U_x(x, t) = 0$  as  $|x| \rightarrow \infty$  and the initial condition  $U(x, 0) = f(x)$ .

(b) From the above solution, identify the Green's function for the equation of heat conduction on the infinite domain  $-\infty < x < \infty, t > 0$ . Physically, the Green's function represents the temperature distribution arising in the presence of a unit heat source located at  $x = \xi$  and activated at time  $t = \tau$ .

IV. (a) Let  $D$  be a set of square matrices which forms a representation of a group  $G$ . Is  $D^*$  also a representation of  $G$ ? Explain.

(b) Let  $D_1$  and  $D_2$  be two representations of a finite group  $G$ . Determine the necessary and sufficient condition that  $D_1$  and  $D_2$  have no irreducible representation in common.

## Comprehensive Exam: Thermodynamics

Tuesday, March 26: 11:30am - 12:30pm

Prob 1: State the three laws of thermodynamics

Prob 2: Assuming the earth to be a sphere of radius 'r' (6400km) find its average equilibrium temperature, if it makes a circular orbit of radius 'D' ( $1.5 \times 10^8$ km) around the sun. The sun, a sphere of radius 'R' ( $7 \times 10^5$ km), radiates as a black body at a temperature  $T_0 = 6000^\circ\text{K}$ . Assume 50% of the radiation is reflected by the earth's atmosphere.

Prob 3:

Suppose that the earth's atmosphere is an ideal gas with molecular weight  $\mathcal{M}$  and that the gravitational field near the surface is uniform and produces an acceleration  $g$ .

(a) Show that the pressure  $p$  obeys the differential equation

$$\frac{dp}{p} = -\frac{\mathcal{M}g}{RT} dz$$

where  $z$  is the height above the surface,  $T$  is the temperature and  $R$  is the gas constant.

(b) Suppose the pressure decrease with height is due to adiabatic expansion. Show that

$$\frac{dp}{p} = \frac{\gamma}{\gamma-1} \frac{dT}{T} \quad \text{where } \gamma = \frac{C_p}{C_v}$$

(c) Evaluate  $dT/dz$  for a pure nitrogen ( $\text{N}_2$ ) atmosphere with  $\gamma = 1.4$  and molecular weight  $\mathcal{M} = 28 \text{ g mol}^{-1}$ . Take  $g = 10 \text{ m s}^{-2}$  and  $R = 8.31 \text{ J mol}^{-1} \text{ K}^{-1}$ .

(d) Suppose that the atmosphere is isothermal with temperature  $T$ . Find  $p(z)$  in terms of  $T$  and  $p_0$ , the sea level pressure.

## Comprehensive Exam: Classical Mechanics

Wednesday, March 27: 9:15 - 10:45am

1. A mass  $m$  orbits another mass  $M$  ( $M \gg m$ ). Assume  $m$  moves in a plane with plane polar coordinates  $r, \theta$ . The mass  $m$  experiences the gravitational pull from  $M$  and a frictional force

$$\mathbf{F}_{\text{frict.}} = -\sigma v_{\theta} \hat{\theta}$$

where  $\sigma$  is a constant,  $v_{\theta}$  the component of the velocity along  $\hat{\theta}$ , which denotes a unit vector in the positive  $\theta$  direction.

- (a) Find the rate of change in the angular momentum  $\ell$  of  $m$ .  
 (b) For  $\sigma = 0$  assume  $m$  moves in a circle of radius  $R$ . Suppose now that  $\sigma \neq 0$  but very small,  $\sigma \ll m\sqrt{MG/R^3}$ , and find the rate of change of  $R$ .
2. A mass  $m$  is tied, using a massless inextensible string of length  $L$ , to a pipe of radius  $a$ . The initial position is as in the figure below

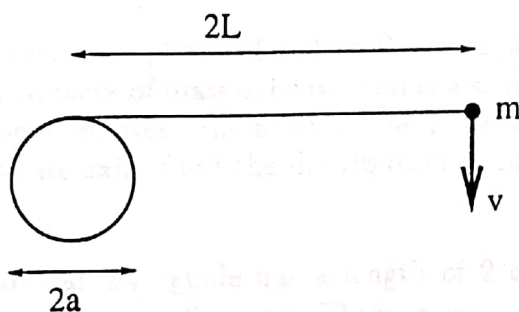

The initial velocity of  $m$  is  $v$  in a direction perpendicular to the string. Find the time it takes for  $m$  to touch the pipe. Ignore gravity and the size of  $m$ .

- (3) A block of mass  $m$  is attached to a spring with spring constant  $k$  on a horizontal plane. The surface to the right of the equilibrium position of the spring is frictionless, while that to the left has friction described by a damping force  $F = -bv$  with  $v$  the velocity. The block is released from rest a distance  $x_0$  to the right of the equilibrium position. Find the maximum distance the block will move to the left of the equilibrium position (assume underdamping). Express your answer in terms of  $x_0$  and the parameters  $\omega_0$  and  $\beta$ , where  $\omega_0 = \sqrt{k/m}$  and  $\beta = b/2m$ .

- (4) A particle is trapped in a non-linear potential of the form

$$U(x) = \frac{kx^2}{2} - \frac{m\lambda x^3}{3}$$

where  $\lambda$  is a small positive number and  $m$  is the particle's mass. The particle executes oscillatory motion.

Using the method of perturbations, find the solution for  $x(t)$  valid to first order in  $\lambda$ ,  $x(t) = x_0(t) + \lambda x_1(t)$ , and the corresponding frequency of oscillation,  $\omega = \omega_0 + \lambda\omega_1$ . The initial conditions are  $x(t=0) = A$  and  $\dot{x}(t=0) = 0$ .

## Comprehensive Exam: Electrodynamics

Wednesday, March 27: 11:00am - 12:30pm

- (1) (i) Use the dipole approximation to find the self inductance  $L$  of a circular loop of radius  $a$  with counterclockwise current  $I$ .  
(ii) If the loop is integrated into an RC circuit to make it an LRC circuit, use Kirchhoff's laws to find the resonant frequency  $\omega$  of the circuit.  
(iii) Qualitatively explain in less than five lines how you would design a metal detector based on the above.
- (2) Circular loop 1 of radius  $a$  is placed coaxially a distance  $c$  above circular loop 2 of radius  $b$ . The loops carry current  $I_a$  and  $I_b$ , respectively, in the counterclockwise direction. If  $c \gg b$  and  $c \gg a$ , find the force between loop 1 and loop 2.
- (3) Two uncharged circular plates of radius  $R$  are separated by a distance  $d$ . A cylindrical piece of material with radius  $a < R$  and height  $d$  is inserted into the center between the plates. The material has a uniform polarization  $\vec{P}$  along its axis. Find the distribution of surface charge on the plates.
- (4) An open rectangular waveguide has a length of 2 cm along the  $x$ -direction and 3 cm along the  $y$ -direction. There is vacuum in the waveguide.
  - (i) What is the minimum frequency of electromagnetic radiation that can be transferred down the guide?
  - (ii) What modes are possible?
  - (iii) What are the phase and group velocities of the mode with the smallest cutoff? What are they for the mode with the largest cutoff? Explain the significance of the phase and group velocities.

# Comprehensive Exam: Thermodynamics

Sept 22, 11:30 A.M.–12:30 P.M.

Do 3 problems.

1. Consider the thermodynamic system in the picture below. The vessel on the left contains compressed gas at high pressure  $P_1$ . The cylinder on the right contains a frictionless piston initially at the left end of the cylinder. Gas at initial pressure  $P_2$  is trapped in the right part of the cylinder. We have  $P_1 > P_2$  so that when the connecting valve is opened, gas slowly leaks into the cylinder and the piston moves slowly compressing the trapped gas until pressure equilibrium is reached. The apparatus is insulated and no heat can flow through the piston.

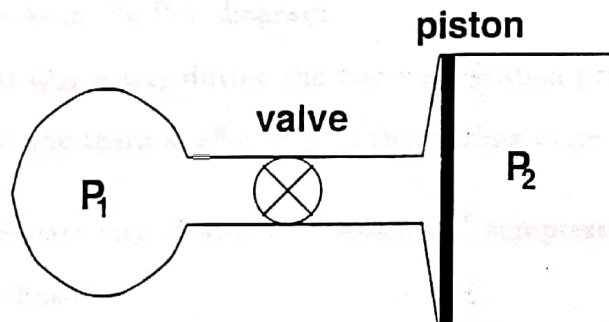

- (a) Does the temperature of the gas in the pressure vessel change? How? Why?
- (b) Does the temperature of the trapped gas change? How? Why?
- (c) Is the gas in the cylinder compressed reversibly or irreversibly? Why?
- (d) Does the gas in the pressure vessel expand reversibly or irreversibly? Why?
- (e) Does the entropy of the Universe change because of the process? How? Why?

2. By integrating the Clausius-Clapeyron equation for the liquid-vapor phase we have

$$\ln P = B - \frac{A}{T},$$

where  $A$  and  $B$  are constants. The vapor is assumed to be an ideal gas and the specific volume of the liquid is neglected.

(a) What is the equation of the vapor saturation curve on a  $P - V$  diagram?

(b) Show that the slope of this curve is steeper than that of an isotherm but not as steep as an adiabatic of an ideal gas with  $\gamma > 1.25$  if  $A/T > 5$ .

3. The Stirling cycle consists of two reversible isothermal heat-transfer processes and two reversible constant-volume processes. During one constant-volume process (2→3), heat  $Q_{23}$  is transferred to an energy-storage device and then transferred back to the working substance during the second constant-volume process (4→1). This is called "regeneration".

(a) Assuming the working substance to be an ideal gas, sketch the T-S diagram for this cycle. Label the end points of each process and use arrows for process directions as in the P-V diagram.

(b) Show that  $Q_{23} = Q_{41}$  during the two regeneration processes.

(c) Show that the thermal efficiency of the Stirling cycle is  $1 - T_L/T_H$ .

4. The volume expansivity  $\beta$  and the isothermal compressibility  $\kappa$  of a material are respectively defined as

$$\beta = \frac{1}{V} \left( \frac{\partial V}{\partial T} \right)_P, \quad \kappa = -\frac{1}{V} \left( \frac{\partial V}{\partial P} \right)_T.$$

(a) Given that an equation of state exists that relates  $V$ ,  $P$ , and  $T$ , show that

$$\frac{dV}{V} = \beta dT - \kappa dP.$$

(b) Now show that the work done by the material in an arbitrary process is  $\delta W = PV\beta dT - PV\kappa dP$ .

(c) Find the work done by an ideal gas using the above expression



# Comprehensive Exam: Electrodynamics

Sept 23, 11:00 A.M.-12:30 P.M.

Do 4 problems.

1. A point charge  $Q$  is located at distance  $r$  from the center of an uncharged, insulated, conducting sphere of radius  $a$ , where  $r > a$ .
  - (a) Find the force between them.
  - (b) What is the surface charge density at the point  $P$  of the sphere nearest to  $Q$ ?
2. Consider a hollow rectangular wave guide of inner dimensions  $a$  and  $b$  along the  $x$  and  $y$  directions. Obtain the explicit  $\vec{E}$  and  $\vec{B}$  fields as functions of  $x$ ,  $y$ ,  $z$ , and  $t$  for the lowest mode of a transverse electric (TE) wave.
3. An electromagnetic plane wave with an electric field of the form  $Ee^{-i\omega t}$  is traveling through a gas containing  $N$  free electrons per unit volume.
  - (a) What is the average induced dipole moment of an electron in the gas?
  - (b) What is the index of refraction of this medium?
  - (c) At what critical value of  $N$  above which the wave will no longer be able to propagate?

4. A conducting rod of length  $L$  lies on top of two conducting rails which are connected by resistance  $R$  to complete the circuit (see the diagram ).

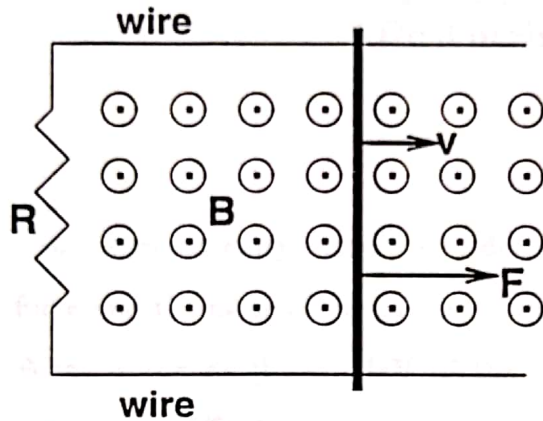

- (a) Calculate the current  $I$  (magnitude and direction) and the force  $F$  required to keep the rod moving at constant velocity  $v$ . The magnetic field is uniform and directed out of the paper.
- (b) Show explicitly that energy is conserved.
5. A thin metallic strip of width  $d$  carries current  $I$ . What is the magnetic field at point  $P$ , which lies in the plane of the strip a distance  $d$  away from one edge?

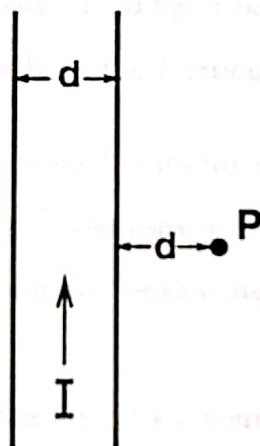

# Comprehensive Exam: Nuclear Physics

Sept 21, 11:30 A.M.–12:30 P.M.

Do 3 problems.

- Use the uncertainty principle to derive the relationship between the range of a force and the mass of the carrier of the force.
  - What is the height in MeV of the Coulomb barrier which inhibits  $\alpha$ -particle emission by  ${}_{92}^{238}\text{U}$ ?
  - What is the probability that a pion of momentum 1 GeV/c can travel a distance of 50 meters without decaying? ( $\tau_{\pi} = 2.6 \times 10^{-8}$  sec,  $m_{\pi} = 140$  MeV/c<sup>2</sup>.)
- ${}^{14}\text{N}$  has excited states at 2.31 and 3.75 MeV above the ground state. If  ${}^{14}\text{N}$  gas is bombarded with 5.0 MeV neutrons, what are the energies of neutrons appearing at 90° with respect to the incident direction?
- Ordinary potassium contains 0.012 percent of the naturally occurring radioactive isotope  ${}^{40}\text{K}$ , which has a half-life of  $1.3 \times 10^9$  y.
  - What is the activity of 1.0 kg of potassium?
  - What would have been the fraction of  ${}^{40}\text{K}$  in natural potassium  $4.5 \times 10^9$  y ago?
- A beam of 0.1 eV neutrons bombards a 1-cm cube of natural uranium metal. If the flux of the beam is  $10^{12}$  neutrons/sec/cm<sup>2</sup>, what is the rate generation in watts of the heat in the block due to the slow-neutron fission of  ${}^{235}\text{U}$  (natural abundance 0.72 percent)?

Note: The fission cross section for 0.1 eV neutrons on  ${}^{235}\text{U}$  is  $2.8 \times 10^{-22}$  cm<sup>2</sup>. The density of uranium is 19 gm cm<sup>-3</sup>. The kinetic energy of the fission fragments is 170 MeV.)

# Comprehensive Exam: Quantum Mechanics

Sept 21, 9:15 A.M.-11:15 A.M.

Do 4 problems.

1. The time-independent Dirac Hamiltonian for a free electron is given by  $H = c\vec{\alpha} \cdot \vec{p} + mc^2\beta$ , where  $\vec{\alpha}$  and  $\beta$  are the  $4 \times 4$  Dirac matrices,

$$\vec{\alpha} = \begin{pmatrix} 0 & \vec{\sigma} \\ \vec{\sigma} & 0 \end{pmatrix}, \quad \beta = \begin{pmatrix} 1 & 0 \\ 0 & -1 \end{pmatrix}.$$

- (a) Calculate the commutator  $[H, L_z]$  where  $L_z$  is the orbital angular momentum of the electron along the  $z$  direction.
- (b) Calculate the commutator  $[H, \Sigma_z]$ , where

$$\Sigma_z = \begin{pmatrix} \sigma_z & 0 \\ 0 & \sigma_z \end{pmatrix}.$$

- (c) From the above results, determine the linear combination of  $L_z$  and  $\Sigma_z$  which commutes with  $H$  and interpret your result in terms of a specific conservation law.

Note:  $\vec{\sigma}$  are the usual  $2 \times 2$  Pauli spin matrices.

2. A particle of mass  $m$  is bound by the spherically symmetric potential

$$V(r) = -\frac{4\hbar^2}{3ma^2} \exp\left(-\frac{r}{a}\right).$$

Use the variation method with the trial function  $e^{-\alpha r}$  to get a good limit on the lowest energy eigenvalue.

3. The Born scattering amplitude is given by

$$f_B(\vec{k}_\beta, \vec{k}_\alpha) = -\frac{m}{2\pi\hbar^2} \int V(\vec{r}) \exp(i\vec{q} \cdot \vec{r}) d^3r, \quad \vec{q} = \vec{k}_\alpha - \vec{k}_\beta,$$

where  $\vec{k}_\alpha$  and  $\vec{k}_\beta$  denote the incoming and outgoing momenta respectively.

- (a) Simplify this in the case of a spherically symmetric  $V$  and obtain the differential scattering cross section for the screened Coulomb potential

$$V(r) = -(Ze^2/r)e^{-r/a}.$$

- (b) State briefly when is the Born approximation expected to be accurate.

4. A particle of mass  $m$  moves in one dimension according to a time-independent potential satisfying  $V(x) = V(-x)$ .

- (a) Let the state function be written as:  $\psi(x, t) = U(t, t_0)\psi(x, t_0)$ . Using the time-dependent Schrödinger equation, derive the general expression for the evolution operator  $U(t, t_0)$ . If  $\psi(x, t_0)$  is an odd function of  $x$ , determine the parity of  $\psi(x, t)$  at any time  $t > t_0$ .

- (b) Let  $\psi(x, t_0) = \delta(x)$  and  $V(x) = 0$ . Calculate  $\psi(x, t)$  in closed form using the results from (a).

5. Consider a one-dimensional harmonic oscillator with the Hamiltonian

$$H = \frac{p^2}{2m} + \frac{m\omega_0^2 x^2}{2}.$$

- (a) Evaluate the commutator  $[a, a^\dagger]$ , where

$$a = (2m\hbar\omega_0)^{-\frac{1}{2}}(p - im\omega_0 x).$$

- (b) Denote the ground state by  $|0\rangle$  (which is annihilated by  $a$ ) and let

$$|\beta\rangle = \sum_{n=0}^{\infty} \frac{\beta^n}{n!} (a^\dagger)^n |0\rangle,$$

where  $\beta$  is an arbitrary complex number. Using the results from (a) evaluate  $a|\beta\rangle$  and also

$$\frac{\langle\beta|H|\beta\rangle}{\langle\beta|\beta\rangle}.$$

# Comprehensive Exam: Mathematical Methods

Sept 22, 9:15 A.M.-11:15 A.M.

Do 4 problems.

1. Consider the differential equation

$$\frac{d^2y}{dx^2} = e^y \quad \text{with} \quad \frac{dy}{dx} = \sqrt{2} \text{ at } y = 0.$$

- (a) Show that  $dx/dy = f(y)$  and find  $f(y)$ .  
(b) Integrate above to obtain  $y(x)$ .

2. Consider an infinite heat conducting slab of thickness  $D$  with one surface ( $x = D$ ) insulated. Initially the temperature  $T$  is zero, then heat is supplied at a constant rate,  $Q$  calories per sec per  $\text{cm}^2$  at the surface  $x = 0$ .

Find the temperature for large  $t > 0$  and  $0 < x < D$  by solving the diffusion equation

$$\frac{\partial^2 T}{\partial x^2} - \frac{1}{\kappa} \frac{\partial T}{\partial t} = 0,$$

where  $\kappa = K/C\rho$ ,  $K$  being the thermal conductivity,  $C$  the specific heat, and  $\rho$  the density of the slab.

**Note:** This is a Neumann boundary problem for which only the large  $t$  solution is required.

3. A function  $f(x)$  has the series expansion  $f(x) = \sum_{n=0}^{\infty} c_n x^n / n!$ . Show that the function  $g(y) = \sum_{n=0}^{\infty} c_n y^n$  can be written as  $\int_0^{\infty} G(x, y) f(x) dx$  and find  $G(x, y)$ .

**Hint:** use integral transforms.

4. Using the method of residues, evaluate the following integral:

$$I = \int_0^{2\pi} \frac{d\theta}{(1 - b \cos \theta)^2},$$

where  $b < 1$ .

5. The character table of the group  $D_3$  (which is the group of the equilateral triangle) is

$D_3$	$E$	$A, B, C$	$D, F$
$T^{(1)}$	1	1	1
$T^{(2)}$	1	-1	1
$T^{(3)}$	2	0	-1

where the elements  $A, B, C$  are rotations through  $\pi$  about the  $A, B, C$  axes shown in the diagram below.

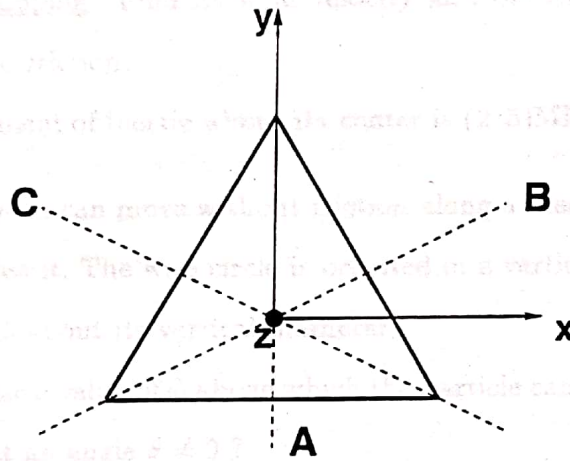

The elements  $D$  and  $F$  are rotations about the  $z$ -axis through angles  $2\pi/3$  and  $4\pi/3$  respectively.

- Construct the character table of the subgroup of  $D_3$  composed of the elements  $E, D, F$  (which is usually called  $C_3$ ).
- Find the coefficients  $m_i$  of the decomposition of the representation  $T^{(3)}$  given by:  $T^{(3)} = \sum_i m_i \tau^{(i)}$ , where  $\tau^{(i)}$  denotes the  $i$ -th irreducible representation of  $C_3$  and the summation is over all distinct  $\tau^{(i)}$ .

# Comprehensive Exam: Mechanics

Sept 23, 9:15 A.M.-10:45 A.M.

Do 4 problems.

1. A uniform solid sphere of mass  $M$  and radius  $R$  resting on a horizontal surface is given an initial push so that it starts to move without rolling with a velocity  $v$ . Since the surface has friction, the sphere eventually reaches the steady state of rolling without slipping. Find its final velocity and the fraction of its initial kinetic energy lost due to friction.

Note: The sphere's moment of inertia about its center is  $(2/5)MR^2$ .

2. A particle of mass  $m$  can move without friction along a massless wire bent in a shape of a circle of radius  $R$ . The wire circle is oriented in a vertical plane and rotated with angular velocity  $\omega$  about its vertical diameter.

- (a) For what critical value of  $\omega$  above which the particle can remain in a fixed position in the wire at an angle  $\theta \neq 0$ ?
- (b) For  $\omega$  below the critical value, if  $m$  is moved slightly away from  $\theta = 0$ , what will be its subsequent motion?

3. A railroad flatcar at mass  $M$  can roll without friction along a straight horizontal track.  $N$  men, each of mass  $m$ , are initially standing on the flatcar which is at rest.

- (a) The  $N$  men run to one end of the flatcar in unison so that their speed relative to the car is  $v_r$  just before they jump off all at the same time. Calculate the velocity of the car after the men have jumped off.
- (b) The  $N$  men run off the car, one after the other (only one man running at a time), each reaching a speed  $v_r$  relative to the car just before jumping off. Find an expression for the final velocity of the car.



(c) In which case, (a) or (b), does the car attain the greater velocity?

4. An observer in an inertial frame sees two spaceships A and B, located at  $(x, y, z) = (0, d, 0)$  and  $(0, 0, d)$ , with uniform velocities  $(v_x, v_y, v_z) = (0, -\beta c, 0)$  and  $(0, 0, -\beta c)$  respectively. Hence they will intercept each other at the origin making an angle of  $90^\circ$  in a time of  $d/\beta c$ . What will be the angle and time of interception as seen by an observer in spaceship B?

5. Find the normal modes and normal frequencies of the linear molecule shown below.

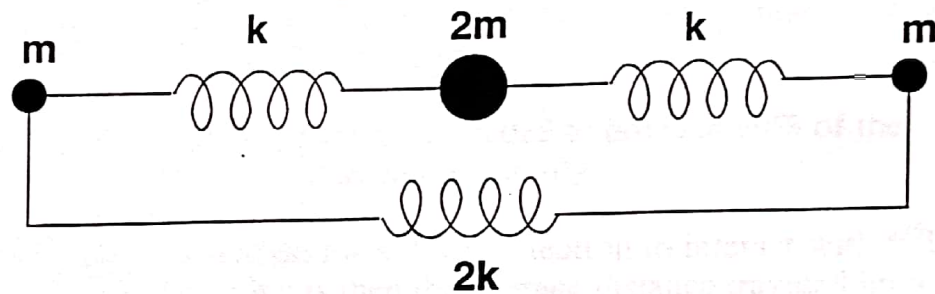

HD

## Comprehensive Examination - Spring 1995

### Nuclear Physics

27th. March 1995 - 11:30 to 12:30 pm

Attempt 3 out of 4 questions.

---

1.) Starting from a pure sample of  $^{23}\text{Na}$ , the nuclide  $^{24}\text{Na}$  is produced at the rate of  $10^8$  per second by neutron bombardment of  $^{23}\text{Na}$ . Compute :

a.) The maximum activity of  $^{24}\text{Na}$  (in Curies) which could be produced.

b.) The bombardment time needed to produce 90% of the maximum activity.

2.) a.) The cross section for a 2 MeV neutron to interact with  $^{235}\text{U}$  is 7 barns. What is then the average distance traveled by a 2 MeV neutron before interacting in a block of  $^{235}\text{U}$ ?

b.) Show that a nuclear power plant producing 1000 MW of heat consumes about 1 kg of  $^{235}\text{U}$  (or other fissionable fuel) per day.

c.) Describe the PPI chain which powers the Sun.

3.) a.) A particle of mass  $M_a$  and kinetic energy  $E_a$  collides with a stationary particle of mass  $M_x$ . Derive an expression for the kinetic energy available in the center-of-mass system of the colliding particles in terms of  $E_a$ ,  $M_a$  and  $M_x$ .

b.) It is desired to study the low-lying excited states of  $^{35}\text{Cl}$  (1.219, 1.763, 2.646, 3.003, 3.163 MeV) through the  $^{32}\text{S}(\alpha, p)^{35}\text{Cl}$  reaction. With incident  $\alpha$  particles of 5.0 MeV which of these excited states can be reached?

# Physics Comprehensive Exam: Quantum Mechanics

March 27, 1995

9:15 – 11:15 am

Do 4 out of 5 problems.

(1) Let  $\psi$  be a bound-state solution of the three-dimensional Schrödinger equation with definite energy. Show that each component of  $\nabla\psi$  (the gradient of  $\psi$ ) is orthogonal to  $\psi$ .

Hint: Use the correspondence principle.

(2) Consider a one-dimensional  $\delta$ -function potential barrier  $V(x) = b\delta(x)$ . Obtain the transmission coefficient for a particle approaching from the left with energy  $E$ .

(3) Consider an arbitrary state (not necessarily an energy eigenstate) of the one-dimensional harmonic oscillator:  $H = p^2/2m + kx^2/2$ . Show that both  $\langle x^2 \rangle$  and  $\langle p^2 \rangle$  are periodic functions of time and obtain their corresponding frequencies.

Hint: Use  $dx/dt = -i\hbar^{-1}[x, H]$ , etc.

(4) Use the WKB method to estimate the number of bound states for a one-dimensional potential  $V(x) = -V_0 \exp(-|x|/a)$ , where  $mV_0a^2/\hbar^2 = 1$ .

(5) Consider a hydrogen atom in its ground state in the presence of a weak external uniform static electric field  $E$  along the  $z$ -direction. Use perturbation theory to find an upper bound on its electric polarizability.

Hint: The unperturbed energy eigenvalues are  $-e^2/2a_0n^2$ . The unperturbed ground-state wavefunction is  $(\pi a_0^3)^{-1/2} \exp(-r/a_0)$ . [ $a_0$  is the Bohr radius.] A useful integral is

$$\int_0^\infty r^n e^{-br} dr = \frac{n!}{b^{n+1}}. \quad (1)$$

# Comprehensive Exam: Mathematical Methods

March 28. 9:15 A.M.-11:15 A.M.

Do 4 problems.

1. Calculate

$$A = \oint_S \mathbf{x} \cdot d\mathbf{S}$$

where  $S$  denotes the surface of a torus;  $\mathbf{x}$  denotes the radius vector and  $d\mathbf{S}$  denotes the element of surface of the torus. The torus is obtained by revolving a vertical circle of radius  $a$  around the vertical axis at a distance  $b$  from the axis.

Express your results in terms of  $a$  and  $b$ .

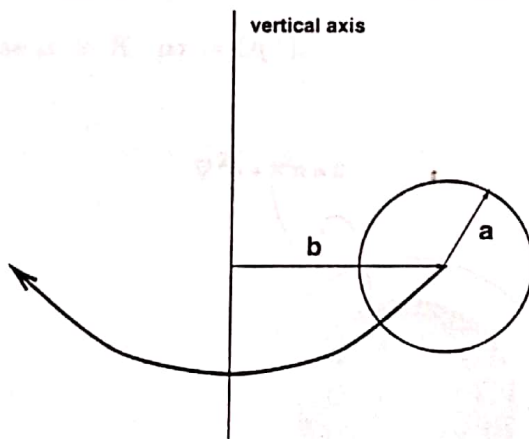

2. Using Laplace transformation techniques solve the integral equation

$$y(t) + \int_0^t y(t') dt' = e^{-t}$$

for  $t > 0$ .

3. Expand the function

$$f(x) = e^{\mu x} \quad -\pi < x < \pi$$

in a Fourier series. By choosing  $x = 0$  find a power series expansion for  $y/\sinh y$ .

4.) a.) Outline the main features of the shell model of the nucleus.

b.) Show that a spin-orbit coupling term in the nuclear potential splits the  $(n, l)$  energy level into two levels whose separation is proportional to  $2l + 1$ .

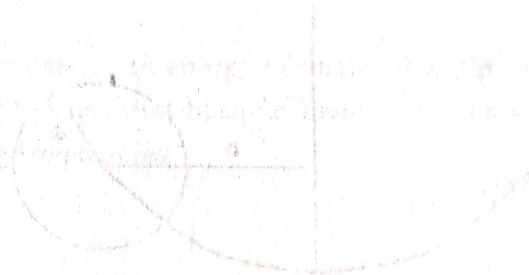

4.

- (a) The neutron density  $n$  inside a chain reacting atomic pile obeys

$$\nabla^2 n + K^2 n = 0$$

Suppose the system is completely spherically symmetric, then, given that the density is non-negative and finite and that it vanishes outside the pile, find the radius of the pile in terms of  $K$  (that is, the point at which  $n$  vanishes).

- (b) Suppose now that the region where the previous equation holds has radius  $R$  and it is surrounded by a surface layer of thickness  $\tau$  where the density obeys

$$\nabla^2 n - \mu^2 n = 0$$

(see the figure below). the density is assumed to vanish at  $r = R + \tau$ ; it is also assumed that both  $n$  and  $\text{grad}n$  are continuous across the interface, find the transcendental equation determining  $R$  in terms of  $\tau$ ,  $\mu$  and  $K$ . Solve this equation approximately in the case  $\mu \gg K$ ,  $\mu\tau = O(1)$ .

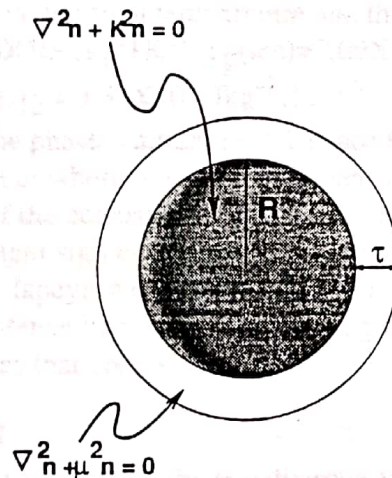

5.

Construct the matrices  $R_x(\theta_x)$ ,  $R_y(\theta_y)$  and  $R_z(\theta_z)$  generating rotations about the  $x$ ,  $y$  and  $z$  axis by angles  $\theta_x$ ,  $\theta_y$  and  $\theta_z$  respectively. Define the matrices  $T_x$ ,  $T_y$  and  $T_z$  by

$$T_x = \left. \frac{dR_x(\theta_x)}{d\theta_x} \right|_{\theta_x=0}; \quad T_y = \left. \frac{dR_y(\theta_y)}{d\theta_y} \right|_{\theta_y=0}; \quad T_z = \left. \frac{dR_z(\theta_z)}{d\theta_z} \right|_{\theta_z=0}$$

Evaluate the commutator

$$[T_x, T_y]$$

in terms of  $T_x$ ,  $T_y$  and  $T_z$ . Interpret your result in terms of the difference between

$$R_x(\theta_x) \cdot R_y(\theta_y) \quad \text{and} \quad R_y(\theta_y) \cdot R_x(\theta_x)$$

for very small values of  $\theta_x$  and  $\theta_y$ .

What is the general name of groups such as this which exhibit this absence of commutativity?



3. (10 pts) Sketch a Carnot cycle for an ideal gas on a:

- P-v diagram,
- u-v diagram,
- u-h diagram,
- T-s diagram,
- P-T diagram.

Label the 4 stopping points on the cycle, a,b,c,d where point a has the highest pressure and the process a→b is the high temperature isothermal expansion. Also label the functional forms of the 4 curved sections on the diagram (for example,  $PV=\text{constant}$ ).

4. (10 pts) A Carnot engine is operated between two heat reservoirs at temperatures of 400K and 300K.

- If the engine receives 1200 Cal from the reservoir at 400K in each cycle, how many Cal does it reject to the reservoir at 300K?
- If the engine is operated as a refrigerator (ie., in reverse) and receives 1200 Cal from the reservoir at 300K, how many Cal does it deliver to the reservoir at 400K?
- How much work is done by the engine in each case?

5. Phase Transitions I

- (5pts) 10 kg of liquid water at temperature of 20°C is mixed in a thermally isolated vessel with 2 kg of ice at a temperature of -5°C at 1 atm pressure until equilibrium is reached. Compute the final temperature and the change in entropy of the system. [ $c_p(\text{water})=4.18 \times 10^3 \text{ J kg}^{-1} \text{ K}^{-1}$ ;  $c_p(\text{ice})=2.09 \times 10^3 \text{ J kg}^{-1} \text{ K}^{-1}$ ; and the specific latent heat of melting  $L_{12} = 3.34 \times 10^5 \text{ J kg}^{-1}$ .]
- (5 pts) Draw the phase diagram in P-T space for a material with 3 phases (solid, liquid, and gas) but where the material expands when frozen, eg., like water. Prove that the slopes of the coexistence lines between solid-liquid, solid-vapor, and liquid-vapor have the right sign and relative magnitude by deriving the relationship known as the Clausius Clapeyron equation for  $(dP/dT)$  along the coexistence lines. [Hint: Along the coexistence line  $dg_1 = dg_2$  where  $g$  is the specific free energy and 1 and 2 are the two phases that coexist].

6. Phase Transition II

- (5 pts) Construct as much of the P-v diagram for  $\text{CO}_2$  as you can. The critical constants of  $\text{CO}_2$  are  $P_c=73 \times 10^5 \text{ Nm}^{-2}$ ,  $T_c=304.2\text{K}$ , and  $v_c=0.094 \text{ m}^3 \text{ kilomole}^{-1}$ . At 299K the vapor pressure is  $66 \times 10^5 \text{ Nm}^{-2}$  and the specific volumes of the liquid and vapor are respectively, 0.063 and  $0.2 \text{ m}^3 \text{ kilomole}^{-1}$ . At the triple point,  $T=216\text{K}$ ,  $P=5.1 \times 10^5 \text{ Nm}^{-2}$ , and the specific volumes of the solid and liquid are respectively 0.029 and  $0.037 \text{ m}^3 \text{ kilomole}^{-1}$ .
- (5 pts) One kilomole of solid  $\text{CO}_2$  is introduced into a vessel whose volume varies with pressure according to the relation  $P=7 \times 10^7 V$ , where  $V$  is in  $\text{m}^3$  and  $P$  in  $\text{Nm}^{-2}$ . Describe the change in the contents of the vessel as the temperature is slowly increased to 310K using the P-v diagram above.



# Comprehensive Exam: Thermodynamics

March 28, 1995 11:30 AM-12:30 PM

There are 6 problems worth 10 points each.

Use the conventions of lower case state variables for density specific variables ( $v=V/N$ ).

Use the convention that a Y-X diagram looks like:

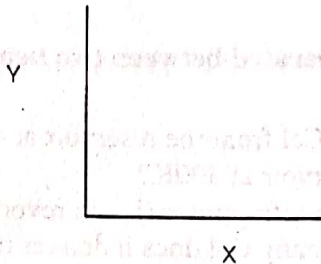

## 1. General processes (10 pts)

- What are the differential forms for  $du$ ,  $dg$ , and  $dh$  using the 1<sup>st</sup> and 2<sup>nd</sup> laws of thermodynamics in terms of  $T, s, P$  and  $v$ .
- What are the coefficients  $A, B, C, D$  in the  $Tds$  equations of the form:

$$Tds = AdT + Bdv \text{ and}$$

$$Tds = CdT + DdP.$$

## 2. Compression and Expansion

- (2 pts) An ideal gas, and a block of copper have equal volumes of  $0.5 \text{ m}^3$  at  $300\text{K}$  and atmospheric pressure. The pressure on both is increased reversibly and isothermally to  $5 \text{ atm}$ . Explain with the aid of a  $P$ - $V$  diagram why the work is not the same in the two processes. In which process is the work done greater?
- (8 pts) On a single  $T$ - $S$  diagram, sketch curves for the following reversible processes for an ideal gas starting from the same initial state. Show the direction and the slope of the line.
  - an isothermal expansion
  - an adiabatic expansion,
  - an isobaric expansion, and
  - an isochoric process in which heat is added.

3.) Consider a uniform square lamina of side  $a$  and mass  $m$  which lies in the  $x$ - $y$  plane of an Cartesian coordinate system. If the origin,  $O$  is at one corner and the  $x$  and  $y$  axes are along two edges calculate :

a.) the inertial tensor of the plate ;

b.) If the plate has an angular velocity of  $\omega = 2\mathbf{i} + 3\mathbf{j}$  about  $O$ , find the kinetic energy of rotation for the plate.

4.) According to Yukawa's theory of nuclear forces, the attractive force between a neutron and a proton inside the nucleus is represented by a potential of the form :

$$V(r) = \frac{k e^{-ar}}{r}$$

where  $k$  and  $a$  are constants and  $k < 0$ .

a.) Find the corresponding force  $F(r)$ .

b.) Calculate the total energy assuming that the particle moves in a circular orbit of radius  $r_0$ .

5.) In a nuclear scattering experiment a beam of 200 GeV protons is elastically scattered of a target consisting of hydrogen gas. If a certain proton is scattered through an angle of 30 degrees in the laboratory, find :

a.) the kinetic energy of the scattered proton;

b.) the kinetic energy of the recoil proton;

c.) the scattering angle in the proton-proton center of mass.

Note : 
$$\frac{\sin \alpha}{1 + \cos \alpha} = \tan (\alpha/2)$$

# Comprehensive Examination - Spring 1995

## Mechanics

29th March 1995 - 9:15 to 10:45

---

Attempt 4 problems.

---

- 1.) A rigid body in the form of a thin uniform rod of length 0.5m is suspended from one end and swings as a physical pendulum. Assuming that the motion is simple harmonic find :

a.) the frequency of oscillation;

b.) the length of an equivalent simple pendulum.

( The radius of gyration of a thin rod of length  $L$  about an axis normal to one end of the rod is  $L/3$  ).

- 2.) A particle of mass 2 kg moves along the  $x$  axis under the influence of two forces. The first is directed towards the origin and has a magnitude  $8x$ . The second is a damping force whose magnitude is numerically equal to 8 times the instantaneous speed. If the particle was initially at rest at a distance of 20 m from the origin find :

a.) the position of the particle as a function of time;

b.) the velocity of the particle as a function of time.

# Comprehensive Examination: Electrodynamics

March 29, 1995 11:00 AM-12:30 PM

There are 4 problems worth 80 points. There are explicit forms of vector operations in spherical coordinates below which you will need.

Spherical  
( $r, \theta, \phi$ )

$$\nabla\psi = \mathbf{e}_1 \frac{\partial\psi}{\partial r} + \mathbf{e}_2 \frac{1}{r} \frac{\partial\psi}{\partial\theta} + \mathbf{e}_3 \frac{1}{r \sin\theta} \frac{\partial\psi}{\partial\phi}$$

$$\nabla \cdot \mathbf{A} = \frac{1}{r^2} \frac{\partial}{\partial r} (r^2 A_1) + \frac{1}{r \sin\theta} \frac{\partial}{\partial\theta} (\sin\theta A_2) + \frac{1}{r \sin\theta} \frac{\partial A_3}{\partial\phi}$$

$$\nabla \times \mathbf{A} = \mathbf{e}_1 \frac{1}{r \sin\theta} \left[ \frac{\partial}{\partial\theta} (\sin\theta A_3) - \frac{\partial A_2}{\partial\phi} \right]$$

$$+ \mathbf{e}_2 \left[ \frac{1}{r \sin\theta} \frac{\partial A_1}{\partial\phi} - \frac{1}{r} \frac{\partial}{\partial r} (r A_3) \right] + \mathbf{e}_3 \frac{1}{r} \left[ \frac{\partial}{\partial r} (r A_2) - \frac{\partial A_1}{\partial\theta} \right]$$

$$\nabla^2\psi = \frac{1}{r^2} \frac{\partial}{\partial r} \left( r^2 \frac{\partial\psi}{\partial r} \right) + \frac{1}{r^2 \sin\theta} \frac{\partial}{\partial\theta} \left( \sin\theta \frac{\partial\psi}{\partial\theta} \right) + \frac{1}{r^2 \sin^2\theta} \frac{\partial^2\psi}{\partial\phi^2}$$

[Note that  $\frac{1}{r^2} \frac{\partial}{\partial r} \left( r^2 \frac{\partial\psi}{\partial r} \right) = \frac{1}{r} \frac{\partial^2}{\partial r^2} (r\psi)$ ]

$$\mathbf{a} \cdot (\mathbf{b} \times \mathbf{c}) = \mathbf{b} \cdot (\mathbf{c} \times \mathbf{a}) = \mathbf{c} \cdot (\mathbf{a} \times \mathbf{b})$$

$$\mathbf{a} \times (\mathbf{b} \times \mathbf{c}) = (\mathbf{a} \cdot \mathbf{c})\mathbf{b} - (\mathbf{a} \cdot \mathbf{b})\mathbf{c}$$

$$(\mathbf{a} \times \mathbf{b}) \cdot (\mathbf{c} \times \mathbf{d}) = (\mathbf{a} \cdot \mathbf{c})(\mathbf{b} \cdot \mathbf{d}) - (\mathbf{a} \cdot \mathbf{d})(\mathbf{b} \cdot \mathbf{c})$$

$$\nabla \times \nabla \psi = 0$$

$$\nabla \cdot (\nabla \times \mathbf{a}) = 0$$

$$\nabla \times (\nabla \times \mathbf{a}) = \nabla(\nabla \cdot \mathbf{a}) - \nabla^2 \mathbf{a}$$

$$\nabla \cdot (\psi \mathbf{a}) = \mathbf{a} \cdot \nabla \psi + \psi \nabla \cdot \mathbf{a}$$

$$\nabla \times (\psi \mathbf{a}) = \nabla \psi \times \mathbf{a} + \psi \nabla \times \mathbf{a}$$

$$\nabla(\mathbf{a} \cdot \mathbf{b}) = (\mathbf{a} \cdot \nabla)\mathbf{b} + (\mathbf{b} \cdot \nabla)\mathbf{a} + \mathbf{a} \times (\nabla \times \mathbf{b}) + \mathbf{b} \times (\nabla \times \mathbf{a})$$

$$\nabla \cdot (\mathbf{a} \times \mathbf{b}) = \mathbf{b} \cdot (\nabla \times \mathbf{a}) - \mathbf{a} \cdot (\nabla \times \mathbf{b})$$

$$\nabla \times (\mathbf{a} \times \mathbf{b}) = \mathbf{a}(\nabla \cdot \mathbf{b}) - \mathbf{b}(\nabla \cdot \mathbf{a}) + (\mathbf{b} \cdot \nabla)\mathbf{a} - (\mathbf{a} \cdot \nabla)\mathbf{b}$$

If  $\mathbf{x}$  is the coordinate of a point with respect to some origin, with magnitude  $r = |\mathbf{x}|$ , and  $\mathbf{n} = \mathbf{x}/r$  is a unit radial vector, then

$$\nabla \cdot \mathbf{x} = 3 \quad \nabla \times \mathbf{x} = 0$$

$$\nabla \cdot \mathbf{n} = \frac{2}{r} \quad \nabla \times \mathbf{n} = 0$$

$$(\mathbf{a} \cdot \nabla)\mathbf{n} = \frac{1}{r} [\mathbf{a} - \mathbf{n}(\mathbf{a} \cdot \mathbf{n})] = \frac{\mathbf{a}_\perp}{r}$$

1. (25 pts) A capacitor is made of two concentric cylinders of radius  $r_1$  and  $r_2$  ( $r_1 < r_2$ ) and length  $L \gg r_2$ . The region between  $r_1$  and  $r_3$  is filled with a circular cylinder of length  $L$  and dielectric constant  $\epsilon_r \epsilon_0$  (the remaining volume is an air gap with dielectric constant  $\epsilon_0$ ).

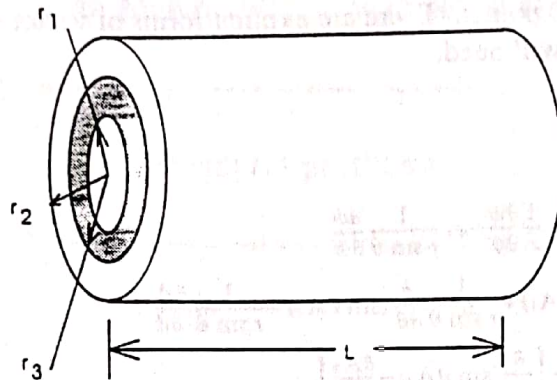

- What is the capacitance? Hint: assume a charge per unit length of  $\lambda$  on the cylinder with radius  $r_1$ .
- What are the values of  $\vec{E}$ ,  $\vec{P}$ , and  $\vec{D}$  at a radius  $r$  in the dielectric ( $r_1 < r < r_3$ )? In the air gap ( $r_3 < r < r_2$ )? Assume a potential difference  $V$  between  $r_1$  and  $r_2$ .
- How much mechanical work must be done to remove the dielectric cylinder while maintaining this constant potential difference between  $r_1$  and  $r_2$ ?
- This is essentially a coaxial cable. Let  $r_3 = r_2$  (eg., the whole space between conductors is filled with dielectric. Let  $\epsilon_r = 5/\pi$ . Let  $r_1 = 1$  mm and  $r_2 = 2.718$  mm [ $\ln 2.718 = 1$ ]. What's  $C$  per unit length. [ $\epsilon_0 = 8.85 \times 10^{-12}$  farad/m.]
- Calculate the self-inductance  $\mathcal{L}$  per unit length of this coaxial cable with  $r_3 = r_2$ . For this purpose the thickness of the conductors can be neglected and the dielectric cylinder is non-magnetic. Assume the same current going to the right in the center conductor is going to the left in the outer conductor.
- Now consider a traveling EM wave propagating down the coaxial cable. What is the complex impedance  $Z$  defined by  $V(z,t) = ZI(z,t)$ . Assume  $I(z,t)$  is the current in the central conductor and has the form  $I_0 \exp(i\omega t - ikz)$  where the propagation constant  $k$  must be chosen to satisfy Maxwell's equations inside the dielectric. [Use  $\sqrt{\mu_0 / \epsilon_0} = 377 \Omega$ ]. Using polystyrene with  $\epsilon_r^{1/2} = 2.67$ , what should  $r_2/r_1$  be to get a  $50 \Omega$  impedance. Isn't it amazing that a circuit with inductance and capacitance can have an overall impedance like a resistor!

2. (15 pts) Prove that  $\nabla^2 \frac{1}{|\vec{r}|} = -4\pi\delta(\vec{r})$  where  $\delta(\vec{r})$  is the delta function. What charge distribution  $\rho(r)$  gives the spherically symmetric potential  $V(\vec{r}) = e^{-\lambda r} / r$ ? Hint: You need the first result as  $r \rightarrow 0$ .

3. (15 pts) Calculate the  $\hat{y}$ -polarized electric field  $E_{y1}$  and  $E_{y2}$  generated from a sheet polarization of the form  $\vec{P} = \hat{y}P_y \exp(ik_x x - i\omega t) \delta(z)$  located at the interface between dielectrics with dielectric constants  $\epsilon = \epsilon_1$  and  $\epsilon = \epsilon_2$ . Assume  $k_x \ll \omega/c$ . Hint: What does Snell's law say about k-vector on two sides of an interface. Hint 2. Determine the boundary conditions for  $E_y$  and  $H_x$  using appropriate loop integrals of the  $\vec{\nabla} \times \vec{E}$  and  $\vec{\nabla} \times \vec{H}$  equations around infinitely small regions at the interface. Note that because of the  $\delta(z)$  function,  $\int_{0^-}^{0^+} \vec{P} dz$  does not vanish as the loop shrinks.

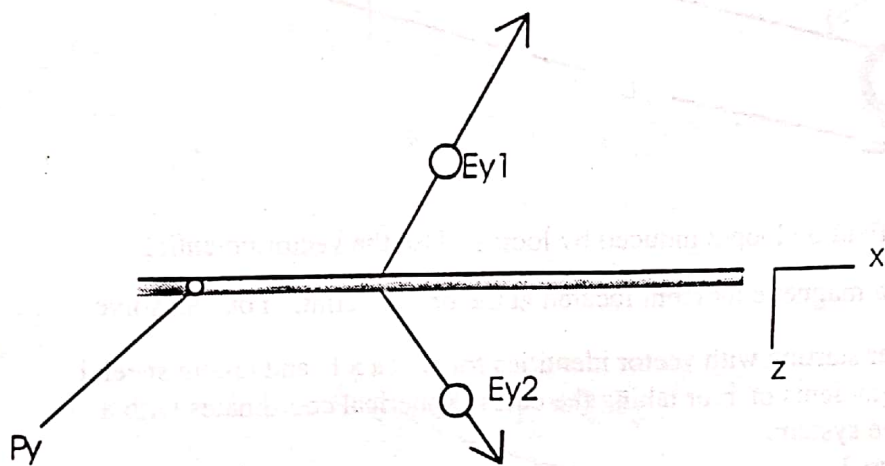

4. (25 pts) Two loops of wire with no resistivity carry the same currents  $I$ , have the same radius  $R$ , and are located a distance  $L$  apart where  $L \gg R$ . The axes of the current loops are parallel and tilted at angle  $\theta$  with respect to their line of centers. The currents travel in the same direction.

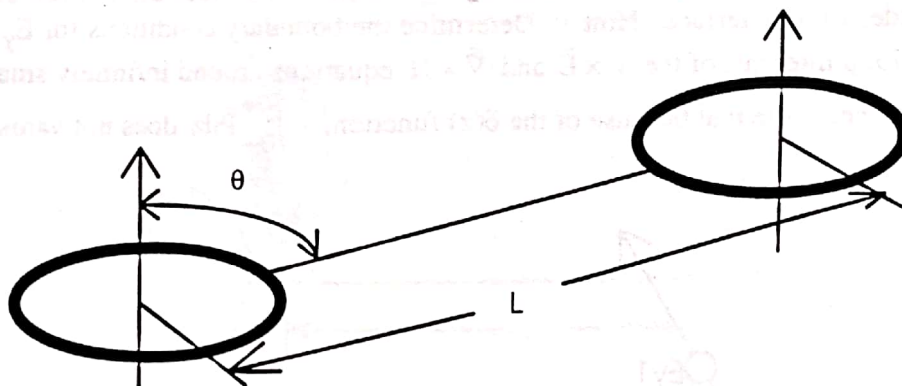

- Find the  $\vec{B}$  magnetic field on loop 2 induced by loop 1. Use the vector potential 
$$\vec{A}(\vec{r}) = \frac{\mu_0}{4\pi} \frac{\vec{m} \times \hat{r}}{r^2}$$
 for a magnetic moment located at the origin. Hint: You can solve this in two ways, either starting with vector identities for  $\nabla \times \mathbf{a} \times \mathbf{b}$  and taking special precautions with the gradients of  $\hat{r}$  or taking the curl in spherical coordinates with a well-chosen coordinate system.
- Find the torque on loop 2.
- What's the energy of this system? Are the loops attracted to each other or repelled?
- If the centers are fixed at length  $L$  but the current loops are free to rotate, what will the equilibrium position be assuming some damping mechanism. Draw the final configuration assuming the system starts with  $\theta < \pi/2$ . Hint, what orientation of the current loops gives the minimum energy.

# Comprehensive Exam: Thermodynamics

March 30, 9-10 A.M.

Do any three problems.

1. One mole of monoatomic ideal gas goes through the reversible cycle shown below.

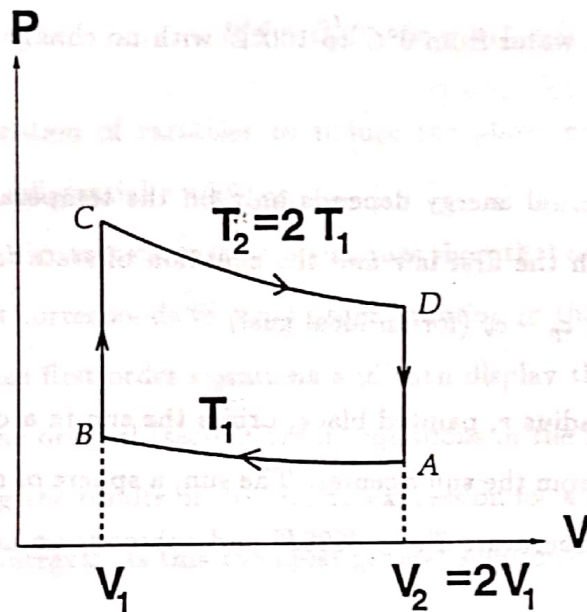

It is compressed isothermally at temperature  $T_1$  from volume  $V_2 = 2V_1$  to volume  $V_1$ , then heated at constant volume to temperature  $T_2 = 2T_1$ . It expands isothermally to volume  $V_2$ , then cooled at constant volume back to temperature  $T_1$ .

- How much work is done by the system in each of the four parts of this cycle?
- How much heat enters the system in each of the four parts of the cycle?
- What is the thermal efficiency of the system? (express your answers in terms of  $V$ ,  $T$  and the gas constant  $R$ ).
- What is the maximum thermal efficiency of a reversible cycle operating between temperatures  $T_1$  and  $T_2 = 2T_1$ ?



2. One kilogram of water at  $0^{\circ}C$  is brought in contact with a large heat reservoir at  $100^{\circ}C$ .

(a) When the temperature of the water has reached  $100^{\circ}C$ , what has been the entropy change in the water? What has been the entropy change of the heat reservoir? What has been the entropy change of the universe?

(b) If the water is heated by first putting it in contact with a reservoir at  $50^{\circ}C$ , and then with the reservoir at  $100^{\circ}C$ , what would have been the entropy change of the universe?

(c) Explain how to heat water from  $0^{\circ}C$  to  $100^{\circ}C$  with no change in the entropy of the universe.

3. For an ideal gas the internal energy depends only on the temperature  $T$ . Use this information together with the first law and the equation of state for an ideal gas to derive an expression for  $c_p - c_v$  (for an ideal gas!).

4. A spherical satellite of radius  $r$ , painted black, orbits the sun in a circular orbit at a distance  $D$  with  $D \gg r$  from the sun's center. The sun, a sphere of radius  $R$ , radiates as a black-body at a temperature  $T_{\odot} = 6000K$  and subtends an arc of  $0.5^{\circ}$  as seen from the satellite.

What is the equilibrium temperature  $T$  of the satellite?

# Comprehensive Exam: Mathematical Methods

March 29, 9-11 A.M.

Do any four problems.

1. Consider the differential equation

$$\partial_x^2 f + \partial_y^2 f + (x + y)f = 0$$

- Use separation of variables to reduce the above equation to two second order ordinary differential equations.
- Using Fourier transformation techniques show that each of the above second order equations corresponds to a first order equation in the Fourier conjugate variable. Solve these first order equations and then display the corresponding solution to each of the original (second order) equations in the form of an integral.
- Collecting the results of (b) find an expression for a solution for  $f$  expressed as a multiple integral. Is this the most general solution?

2. Use complex integration techniques to evaluate the following integrals. Should one of the poles lie on the integration contour use the principal value definition

(a) First integral,

$$\mathcal{I} = \int_0^{2\pi} \frac{dx}{a + \cos x}.$$

(b) Second integral,

$$\mathcal{J} = \int_{-\infty}^{\infty} \frac{\ln(1+x^2)}{a^2+x^2} dx; \quad 0 \leq a < 1$$

3. Consider the following figure

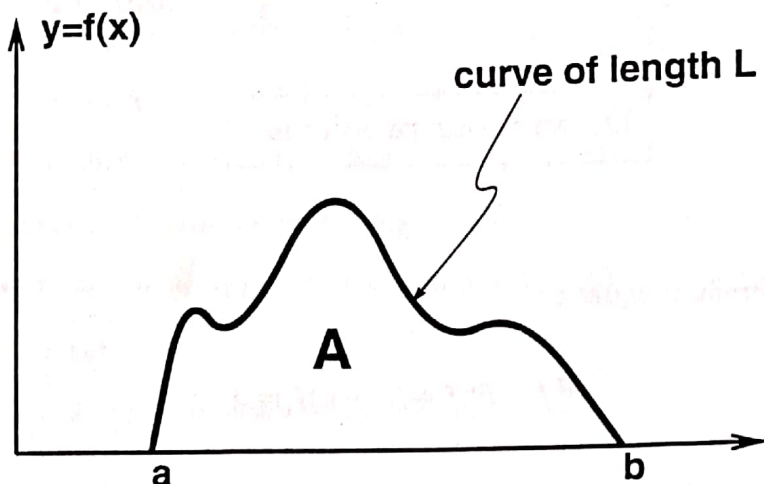

in which we have a curve  $y = f(x)$  which together with the  $x$ -axis segment  $a \leq x \leq b$ , bounds an area  $A$ . The length of the curve is *fixed* to be  $L$ . Find, using variational calculus, the expression for  $f(x)$  which extremizes  $A$ . The boundary points are also assumed to be fixed, that is,

$$f(a) = f(b) = 0 \quad \text{for any } f.$$

**Hint:** Impose the constraint that the length is  $L$  for any choice of  $f$  by the method of Lagrange's undetermined multipliers.

4. Consider the differential operator

$$\mathcal{O} = -\nabla^2 + 1 - i\partial_t$$

(a) Find the period retarded Green's  $G_R$  function for  $\mathcal{O}$ , that is, the solution to the equation

$$\mathcal{O}G_R(\mathbf{r}, t) = \delta(\mathbf{r})\delta(t)$$

$$G_R(\mathbf{r}, t) = 0 \quad \text{for } t < 0$$

$$G_R(\mathbf{r}, t) = G_R(\mathbf{r} + L\hat{x}, t) = G_R(\mathbf{r} + L\hat{y}, t) = G_R(\mathbf{r} + L\hat{z}, t)$$

where  $\hat{x}$  denotes a unit vector in the  $x$  direction and similarly for  $\hat{y}$  and  $\hat{z}$ . i.e., imagine a cubic box of size  $L$  and require  $G_R$  to have period  $L$  in any direction.

**Hint:** Expand  $G_R$  in Fourier series in  $\mathbf{r}$  with  $t$  dependent coefficients. Determine an equation for these coefficients and solve it using Fourier transformation techniques.

(b) Using the above result find the function  $\psi$  satisfying

$$\mathcal{O}\psi(\mathbf{r}, t) = 0$$

with initial conditions

$$\psi(\mathbf{r}, t = 0) = \delta(\mathbf{r})$$

5. Consider the equation

$$\ddot{x} + \omega^2(t)x = 0$$

where a dot denotes derivative with respect to  $t$  and the function  $\omega(t)$  is periodic with period  $T$ ,

$$\omega(t) = \omega(t + T).$$

- (a) Consider the group generated by translating  $t$  by  $nT$ , ( $n = 0, \pm 1, \pm 2, \dots$ ) under which  $\omega$  is invariant. Show that this group is Abelian. What is the dimension of any irreducible representation?
- (b) Assume that the solutions carry a representation of the above group. Based on the results of part (a), what is the general form of these solutions? What is their behaviour under  $t \rightarrow t + T$ ?

# Comprehensive Exam: Electromagnetism

March 28, 1-2 P.M.

Do any three problems.

Some constants:

$$m_e = 9.11 \times 10^{-31} \text{ kg}$$

$$e = 1.602 \times 10^{-19} \text{ C}$$

$$\epsilon_0 = 8.85 \times 10^{-12} \text{ C}^2/(\text{Nm}^2)$$

$$\mu_0 = 4\pi \times 10^{-7} \text{ N/A}^2$$

$$c = 3 \times 10^8 \text{ m/s}$$

1.

- (a) Calculate the resistive and reactive components of the ac impedance  $Z_{\text{tank}}$  looking into the parallel resonant "tank" circuit of Fig. 1. Assume that  $R$  is large compared to all other impedances. Find the resonant frequency  $\omega_0$  of the tank circuit.

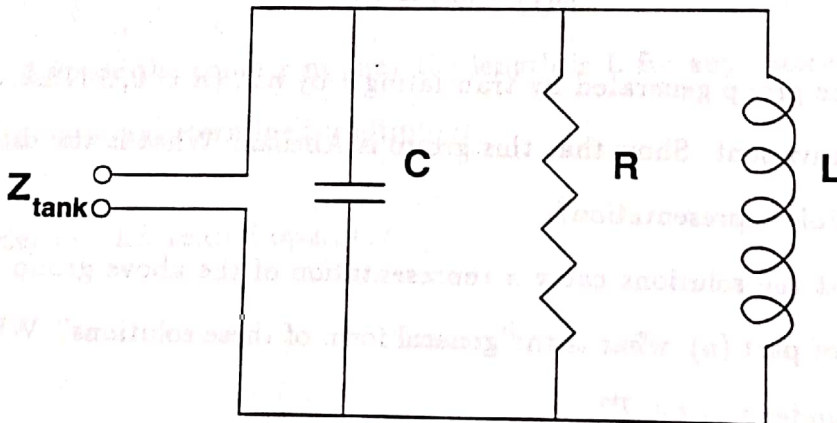

Fig. 1

- (b) Find an expression for the frequency  $\omega_{op}$  at which the resistive part of  $Z_{\text{tank}}$  is an arbitrary value  $Z_c < R$ , and the reactive part of  $Z_{\text{tank}}$  is *inductive*. (You do not need to solve this expression for  $\omega_{op}$ ). Is  $\omega_{op}$  higher or lower than  $\omega_0$ ?
- (c) Find the value of  $C_m$  in Fig. 2 such that the impedance  $Z$  looking into this circuit is entirely resistive and equal to  $Z_c$ .

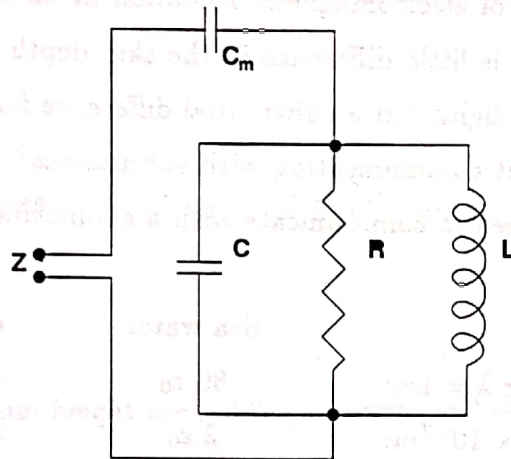

Fig. 2

- (d) State the general condition for maximum power transfer from an ac generator (with an internal resistance) to a load impedance.
- (e) An ac voltage generator of internal resistance  $r$  is attached to the terminals of the circuit in Fig. 2. Find the relation between  $r$ ,  $R$ ,  $L$ , and  $C$  which maximizes the power transfer from the generator to the resistance  $R$ . Again assume  $R$  is large compared to all other impedances.
2. A sphere of radius  $a$  has a total charge  $Q$  distributed uniformly over its surface. Find the stress (force per unit area) on the surface.
3. In a classical "Bohr" model of the hydrogen atom, the electron rotates in a circular orbit of radius  $a_0$  about the proton.
- (a) Determine the angular speed of the electron.
- (b) Find the electric current which is equivalent to the circulating electron.
- (c) Calculate the magnetic field at the proton due to the orbiting electron.
- Express your answers to parts (a), (b), and (c) above in terms of the electronic charge  $e$ , the electron mass  $m$ , the Bohr radius  $a_0$ , and any other appropriate constants.

4. Two long coaxial cylindrical metal tubes stand vertically, one inside the other, in a tank of dielectric oil with susceptibility  $\chi_e$ , and mass density  $\rho$ . The inner one has radius  $a$  and is maintained at a potential  $V$ . The outer tube has radius  $b$  and is grounded. To what depth or height  $h$ , does the oil rise in the space between the tubes? Let  $h$  be positive if the oil rises and negative if the oil level goes down.
5. Consider the skin depth of electromagnetic radiation at an air-water surface. Show quantitatively that there is little difference in the skin depth between distilled water and salt water for visible light, but a substantial difference for 1 meter radio waves. What does this say about communicating with submarines? In particular, how long an antenna would you need to communicate with a submarine about 50 m below the surface?

	Sea water	Distilled water
Dielectric constant for $\lambda = 1m$ :	$80 \epsilon_0$	$80 \epsilon_0$
Dielectric constant for $\lambda = 5 \times 10^{-7}m$ :	$2 \epsilon_0$	$2 \epsilon_0$
Resistivity for $\lambda = 1m$ :	$5 \times 10^{-2}$ ohm-meter	$5 \times 10^{-3}$ ohm-meter
Resistivity for $\lambda = 5 \times 10^{-7}m$ :	$5 \times 10^{-2}$ ohm-meter	$5 \times 10^{-3}$ ohm-meter

# Comprehensive Exam: Mechanics

DATE

Do all three problems.

Some constants:

$$G = 6.67 \times 10^{-11} \text{ N} \cdot \text{m}^2/\text{kg}^2 \quad M_{\text{earth}} = 6 \times 10^{24} \text{ kg} \quad R_{\text{earth}} = 6.4 \times 10^6 \text{ m}.$$

1.

- (a) Two men of equal height are holding opposite end of a long, uniform, horizontal plank of mass  $M$ . One man drops his end. What is the amount of weight (force) that the other man feels before the plank hits the ground?
- (b) Consider a disk of mass  $m$  sliding on a smooth surface. It oscillates in a simple harmonic motion in a straight line under the influence of two equal springs, each of spring constant  $k$ , and negligible mass.

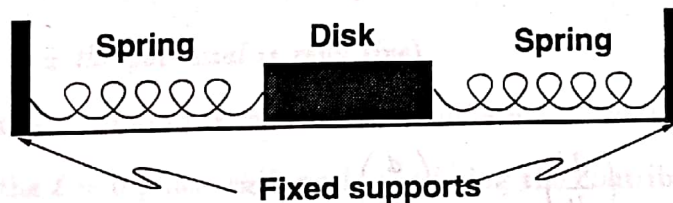

Find the effect on the amplitude and frequency of the motion of the disk if a piece of putty, also of mass  $m$ , is dropped vertically on the disk:

- i. When the disk is at the extreme end of its oscillation
- ii. When the disk is at the center of its oscillation



2.

(a) A point mass  $m$  is fired from infinity with speed  $v_0$  toward a sphere of mass  $m$  and radius  $R$ . The only force between the masses is gravity. For what range of impact parameters does the incoming mass hit the sphere?

(b) A rocket plus fuel at takeoff from the earth has a mass  $M$ . The rocket exhaust is expelled backward at a speed  $v_e$  relative to the rocket. The fuel is fully burned in  $T$  seconds and the rocket then has just enough speed to escape. What is the final mass of the empty rocket. [Assume that the pull of the earth's field can be described by the same constant  $g$  during the burning. You must calculate the escape velocity yourself i.e. show the calculation.]

3. A ballistic projectile is launched with an initial speed of 500 m/s southward, at an angle  $30^\circ$  from the horizontal. This is done on earth at a latitude of  $60^\circ$  north of the equator. Neglect frictional effects.

(a) Assume that the earth did not rotate. Calculate the point of impact.

(b) Calculate the real point of impact taking into account the earth's rotation.

**Hint:** assume that we label a rotating coordinate system by the subscript "rot", and the fixed coordinate system with the subscript "space." Then from Goldstein 4-102 we can write

$$\left(\frac{d}{dt}\right)_{\text{space}} = \left(\frac{d}{dt}\right)_{\text{rot}} + \boldsymbol{\omega} \times$$

# Comprehensive Exam: Quantum Mechanics

March 28, 9–11 A.M.

Do any four problems.

1. Consider a particle moving in three dimensions in the presence of an *attractive* spherically symmetric potential,

$$V(r) = A\delta(r - a); \quad A < 0.$$

- (a) Restrict yourself to the zero angular momentum case and find a transcendental equation that determines the negative energy eigenvalues. Are there solutions for all values of  $A$ ?

- (b) For non-zero angular momentum find the zero energy eigenfunctions.

*Hint:* Try solutions of the form  $r^\nu$  for the radial wave-functions in part b.

2. Consider a particle moving in three dimensions in the presence of a *repulsive* spherically symmetric potential,

$$V(r) = A\delta(r - a); \quad A > 0$$

(note that now the potential is repulsive).

- (a) Find the Born approximation to the differential scattering cross section.
- (b) Find the  $\ell = 0$  phase shift and, neglecting the contributions from  $\ell \geq 1$ , find an approximation to the differential scattering cross section.
- (c) When are the above approximations to the scattering cross section expected to be valid?

The relevant spherical Bessel functions and spherical harmonics are

$$j_0(z) = \frac{\sin z}{z}; \quad n_0(z) = -\frac{\cos z}{z}; \quad Y_0^0(\theta, \phi) = \frac{1}{\sqrt{4\pi}}$$

3. Consider a particle of mass  $\mu$  moving in a time independent magnetic field whose vector potential is

$$A = (Bx) \hat{y}$$

where  $\hat{y}$  is the unit vector in the  $y$  direction and  $B$  is a constant. The scalar potential vanishes.

- (a) Find the Hamiltonian and two operators that commute with it.  
 (b) Use the above results to find the eigen-energies of the system.

**Hint:** The energies of a harmonic oscillator of frequency  $\omega$  are  $\frac{1}{2}\hbar\omega(2n + 1)$ ,  $n = 0, 1, 2, \dots$

4. A hydrogen atom is placed in a time-dependent homogeneous electric field given by

$$\mathbf{E}(t) = \frac{A\tau}{t^2 + \tau^2} \hat{z}$$

where  $\hat{z}$  is the unit vector in the  $z$ -direction,  $A$  is a constant and  $\tau$  is a characteristic time constant. If at  $t = -\infty$  the atom is in its ground state, calculate the probability  $P$  that at  $t = +\infty$  it has made a transition to the first excited state. Show that if  $\tau$  is very large the probability is very small and estimate the value of  $\tau$  for which  $P \ll 1$ .

You may use the following spherical harmonics and hydrogen radial wavefunctions

$$(\psi_{nlm} = R_{nl}Y_{lm})$$

$$Y_{00} = \frac{1}{\sqrt{4\pi}}$$

$$Y_{10} = \sqrt{\frac{3}{4\pi}} \cos \theta$$

$$R_{10} = \left(\frac{1}{a_0}\right)^{3/2} 2e^{-r/a_0}$$

$$R_{21} = \left(\frac{1}{2a_0}\right)^{3/2} \frac{r}{a_0\sqrt{3}} e^{-r/2a_0}$$

The following integral may also be required

$$\int_0^{\infty} e^{-\alpha x} dx = \alpha^{-1}$$

5. A simple harmonic oscillator in one dimension with unperturbed Hamiltonian

$$H_0 = \frac{p^2}{2m} + \frac{1}{2}m\omega^2 x^2$$

is subjected to a perturbation

$$\lambda H_1 = \frac{1}{2}\lambda m\omega^2 x^2$$

where  $\lambda$  is a dimensionless constant such that  $\lambda \ll 1$ .

- (a) Use *perturbation theory* to calculate the energy levels of the perturbed oscillator up to order  $\lambda^2$ .
- (b) Find an expression for the ground state eigenket in terms of the unperturbed eigenkets up to  $O(\lambda)$ .
- (c) Calculate the energy levels of the perturbed oscillator *directly* and compare your result with that obtained in part (a).

# Comprehensive Exam: Nuclear Physics

March 29, 1-2 P.M.

Do any four problems.

1. Suppose that the density of nucleons  $\rho$  in a nucleus varies with radial distance  $r$  from the center of the nucleus as shown in the figure below. What fraction of the nucleons lie in the surface region in the nuclei  $^{27}\text{Al}$ ,  $^{125}\text{Te}$  and  $^{216}\text{Po}$  if  $\rho_0 = 0.17F^{-3}$ ,  $c = 1.1A^{1/3}F$ , and  $a = 3.0F$ ?

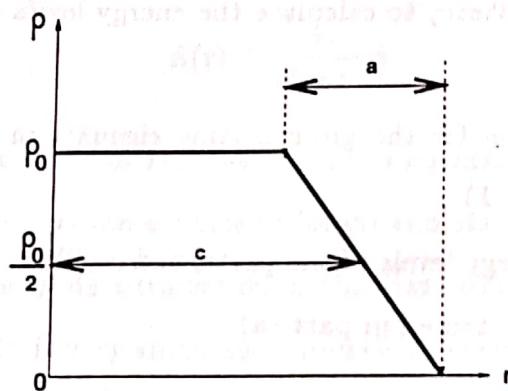

2.

- (a) Describe the main elements of the shell model of nuclei.
- (b) Use the shell model to predict the ground state nuclear spin and parity for the following nuclei:  $^{16}_8\text{O}$ ,  $^{17}_8\text{O}$ ,  $^{18}_8\text{O}$ ,  $^{15}_7\text{N}$ ,  $^{14}_7\text{N}$ .
- (c) In the shell model of the nucleus the spin-orbit coupling potential  $V$  has the form

$$V \propto \mathbf{L} \cdot \mathbf{S}$$

i

where  $L$  is the orbital angular momentum and  $S$  is the spin angular momentum. This potential splits the energy levels. Calculate the difference between the expectation values  $\langle L \cdot S \rangle$  of the split energy levels in terms of the orbital angular momentum quantum number  $l$ .

3. A nucleus of mass number  $A$  makes a transition from an excited state to the ground state by emission of a gamma ray.

(a) What is the difference between the excitation energy and the gamma ray energy  $E_\gamma$  due to the fact that the nucleus recoils?

(b) If the above gamma ray is absorbed by a second nucleus of mass number  $A$ , to what energy can it excite the second nucleus? Apply your results to the case of the  $^{57}\text{Fe}$  nucleus which emits a  $14\text{keV}$  gamma ray.

4. A tritium target (at rest in the lab system) is bombarded with a beam of protons (of rest mass  $m_p = 938.5\text{MeV}$ ) in order to produce neutrons.

(a) Calculate the minimum kinetic energy of the protons required to produce neutrons with a maximum kinetic energy of  $2.0\text{MeV}$ .

(b) Calculate the minimum kinetic energy of the emitted neutrons.

You may use the following equation for the  $Q$  value of the reaction  $a + X \rightarrow b + Y$ :

$$Q = T_b \left(1 + \frac{M_b}{M_Y}\right) - T_a \left(1 - \frac{M_a}{M_Y}\right) - \frac{2}{M_Y} (M_a T_a M_b T_b)^{1/2} \cos\theta$$

5. The radioactive nuclide  $^{24}\text{Na}$  ( $t_{1/2} = 14.8$  hours) can be produced by neutron bombardment of  $^{23}\text{Na}$ . If the production rate of  $^{24}\text{Na}$  is  $10^8\text{sec}^{-1}$ , and the bombardment is started with a fresh sample of  $^{24}\text{Na}$ , calculate (a) the maximum activity of  $^{24}\text{Na}$  (in Curies;  $1\text{Curie} = 3.7 \times 10^{10}\text{disintegrations/s}$ ) which could be produced, (b) the bombardment time needed to produce 90% of the maximum activity, (c) the number of radioactive atoms of  $^{24}\text{Na}$  left 3 hours after the bombardment of part (b) was

stopped.

This part of the question is about the difference between the kinetic energy of the alpha particle and the energy of the alpha particle.

Assume that the alpha particle is emitted from the nucleus.

Calculate the kinetic energy of the alpha particle.

A nucleus of mass number  $A$  makes a transition from an excited state to the ground state by emission of a gamma ray.

(a) What is the difference between the excitation energy and the kinetic energy of the alpha particle? Show that the difference is small compared to the kinetic energy of the alpha particle.

(b) The alpha particle is emitted with a kinetic energy  $K$ . What energy can be emitted by the nucleus? Show that the energy of the gamma ray is small compared to the kinetic energy of the alpha particle.

the  $\gamma$  ray nucleus which emits a  $\gamma$  ray.

2. A tritium nucleus (at rest in the lab system) is bombarded with a beam of protons (at rest mass  $m_p = 1.67 \times 10^{-27}$  kg) in order to produce neutrons.

(a) Calculate the maximum kinetic energy of the proton required to produce neutrons with a maximum kinetic energy of 0.1 MeV.

(b) Calculate the minimum kinetic energy of the emitted neutrons.

You may use the following equation for the  $Q$  value of the reaction  $a + b \rightarrow c + d$ .

$$Q = (M_a + M_b - M_c - M_d)c^2 = (M_a + M_b - M_c - M_d) \times 931.5 \text{ MeV}$$

3. The radioactive nuclide  $^{238}\text{U}$  (half-life  $T_{1/2} = 4.468 \times 10^9$  years) decays to  $^{234}\text{Th}$  by emitting an alpha particle.

(a) Calculate the maximum kinetic energy of the alpha particle.

(b) Calculate the maximum kinetic energy of the  $^{234}\text{Th}$  nucleus.

(c) Calculate the maximum kinetic energy of the gamma ray.

(d) Calculate the maximum kinetic energy of the beta ray.

(e) Calculate the maximum kinetic energy of the positron.

## ELECTROMAGNETISM Spring '97

(Answer all questions)

**1. Faraday used this technique to measure the flow rate of the Thames River:** Water (conductivity ' $\sigma$ ') is flowing with speed ' $v$ ' in a horizontal channel of depth ' $w$ ' and width ' $l$ ' in a region where the vertical component of the magnetic induction due to the earth is  $B_d$ . Two metal electrodes are placed opposite each other on the side walls of the channel. The electrodes are rectangular of dimensions ' $a$ ' and ' $b$ ' and are at the same distance ' $d$ ' from the bottom of the channel with the long edges horizontal. Find

- The resistance of the fluid column contained in the rectangular parallelepiped between the electrodes
- the induced emf between the electrodes
- The resultant current if the electrodes are connected by a wire of negligible resistance outside the channel.

(15 points)

**2. This is a problem on the first thing that happens when you turn the ignition in your car:** A solenoid of ' $n$ ' turns per meter, cross sectional area ' $A$ ' surrounds part (pick any length) of a cylindrical piece of magnetic material with permeability ' $\mu$ ' of the same cross sectional area ' $A$ ' such that the magnetic material can slide into or out of the solenoid easily. If the current ' $I$ ' in the solenoid flows in the positive  $\phi$  direction,

- find the  $\mathbf{B}$  field inside the magnetic material
- find the mutual interaction energy
- find the direction and magnitude of the force on the bar magnet
- Is there a force if the solenoid were an ideal solenoid. Explain

(20 points)

- 3.**
- Write Maxwells equations in vacuum far away from stationary or moving charges
  - Get the wave equation on the electric field from the Maxwell equations and show that  $\mathbf{E} = E_0 \sin(kz - \omega t) \mathbf{y}$  is an allowed solution.
  - Find the corresponding  $\mathbf{B}$
  - If there is a magnetic dipole antenna on your TV of radius ' $a$ ' (circular loop of wire). Which way should you orient the antenna to maximise the signal i.e to maximize the emf around the loop. Calculate this emf at time ' $t$ ' using the assumption that the wavelength ' $\lambda$ ' is much larger than ' $a$ ' (as TV wavelengths are about 3 meters long and the radius of the antenna is about 0.1 meters)
  - After you are done optimizing the direction give at least two easy ways of increasing your TV reception.

(25 points)



## Comprehensive Exam: Quantum Mechanics

There are 3 problems which are divided into sections. Problems 1 and 2 are worth 20 points each. Problem 3 is worth 60 points.

*Problem 1* - A particle is moving in a infinitely deep well which is given by:  $V(x) = 0$  if  $-a < x < a$  and  $V(x) = \infty$  if  $|x| > a$ .

A) Solve the Schrödinger equation for this potential. Find the spectrum and the *normalized* wave functions. Draw a figure of the ground state and the first two excited states and give their energy.

B) Suppose another potential is added to the one above. This potential is given by  $V_{extra}(x) = V_0\delta(x)$  where  $\delta(x)$  is a Dirac delta function ( $V_0 > 0$ ). Write down the Schrödinger equation and by using the appropriate boundary conditions at  $x = 0$  and find the eigenfunctions of the problem. Compare *qualitatively* the spectrum of this problem with the one of part A). Show that we can recover the spectrum in A) if you set  $V_0 \rightarrow 0$ . Discuss what happens when  $V_0 \rightarrow \infty$ . Give a *qualitative* discussion of what happens when  $V_0$  becomes negative. **Hint:** Integrate the Schrödinger equation from  $-\epsilon$  to  $\epsilon$  and make  $\epsilon \rightarrow 0$  in order to obtain the boundary condition at  $x = 0$ .

*Problem 2* - A non-spherical charged atom has an electric dipole moment that oscillates. This atom is in the ground state when an external homogeneous electric field is applied. The potential created by the external field is:  $V_{ext}(x) = -Fx$ . Assume that the dipole can be described in terms of an one-dimensional harmonic oscillator with frequency  $\omega_0$  and effective mass  $m$ . The field is applied in the direction of motion. Determine the probability that the oscillator remains in the ground state after  $F$  is applied. *Hint:* Make a drawing of the total potential as a function of  $x$  for various values of  $F$ . The ground state wave function of the harmonic oscillator is:

$$\Psi_0(x) = \left(\frac{m\omega_0}{\pi\hbar}\right)^{1/4} e^{-m\omega_0 x^2/(2\hbar)}$$

and you will probably need to use the integral:

$$\int_{-\infty}^{+\infty} dx e^{-ax^2+bx} = \sqrt{\frac{\pi}{a}} e^{b^2/(4a)}.$$

*Problem 3* - A molecule is made out of two atoms with spin 1/2. A) If the two atoms do not interact with each other what are the possible configurations for this problem in the basis of the operator  $S^z$ ? **Use a notation**

such that the eigenstates of  $S^z$  are  $|\uparrow\rangle$  represents an up spin and  $|\downarrow\rangle$  represents a down spin.

B) Consider now the case where the spins interact antiferromagnetically, that is, the Hamiltonian of the system is given by

$$H_0 = \frac{2\epsilon_0}{\hbar^2} S_1^z S_2^z \quad (1)$$

where  $S_i^z$  with  $i = 1, 2$  represents each one of the atoms and  $\epsilon_0$  is the energy scale. What are the eigenstates and eigenenergies of the system? Are there any degenerate states?

C) A very weak magnetic field is applied to the atom 2. The interaction between the magnetic field and the atom can be represented by the perturbation

$$V_1 = -\frac{2\Delta}{\hbar} S_2^z. \quad (2)$$

What are the energies of the states in the presence of  $V_1$ ? Are the states degenerate? Is there a value of  $\Delta$  for which the states become degenerate? What is the lowest energy state?

D) Consider now the possibility that one of the spins can tunnel from one configuration to another. The simplest way to describe the tunneling is via the Hamiltonian

$$H_t = \frac{2\lambda}{\hbar} S_1^x \quad (3)$$

where  $\lambda$  is the tunneling energy and  $S_1^x$  is the  $x$ -component of the spin 1. Assume now that  $\Delta, \lambda \gg \epsilon_0$  (that is, you can set  $\epsilon_0 = 0$  and the Hamiltonian becomes  $H = V_1 + H_t$ ). Assume that  $H_t$  is a perturbation to  $V_1$ . Calculate in the *leading* order (non-zero!) in perturbation theory the shift in the energies and eigenstates of  $V_1$ . Solve the problem exactly and compare with the results of perturbation theory. What do you conclude?

E) Assume that (3) is a perturbation to (1) and disregard  $V_1$ . Calculate in the *leading* order (non-zero!) in perturbation theory the shift in energy and eigenstates of (1). Solve the problem  $H = H_0 + H_t$  exactly and compare with the result of the perturbation theory.

Hint: the spin operators  $S^z$  and  $S^x$  can be written as  $S^z = \hbar\sigma^z/2$  and  $S^x = \hbar\sigma^x/2$  where  $\sigma^z$  and  $\sigma^x$  are the Pauli matrices:

$$\sigma^z = \begin{bmatrix} 1 & 0 \\ 0 & -1 \end{bmatrix}$$

$$\sigma^x = \begin{bmatrix} 0 & 1 \\ 1 & 0 \end{bmatrix}$$

1. Expand the function  $f(x) = x + x^2$  in Fourier Series in the interval  $(-\pi, \pi)$ . Use your answer to obtain the infinite sum  $\sum_{n=1}^{\infty} \frac{1}{n^2}$ .

2. Solve the Laplace's equation  $\frac{\partial^2 \phi}{\partial x^2} + \frac{\partial^2 \phi}{\partial y^2} = 0$  inside a semi-infinite strip  $x > 0, 0 < y < a$  with the boundary condition  $\phi(x, y) = f(x)$  at  $y = 0$ ;  $\phi = 0$  at  $x = 0$  and  $y = a$ .

3. Determine the one-dimensional green's function  $g(x, x')$  for:

$$\frac{d^2 g}{dx^2} + k^2 g = \delta(x - x') \quad \text{with } 0 < x < a: g(0) = 0 = g(a).$$

Obtain your answer *without* expressing  $g$  as a sum of an infinite set of orthonormal functions.

4. a) Prove that the set of elements  $a_i$  in group  $G$  such that  $a_i x = x a_i$  for all  $x$  in  $G$  is a subgroup of  $G$ .

- b) Consider the following infinitesimal transformation on the coordinates  $x, y, z$ :

$$x' = x$$

$$y' = y + \epsilon z$$

$$z' = \epsilon x + z$$

Determine the generator of this transformation, and from it, obtain the matrix for the finite transformations in an exponential form.

The following may be useful:

Gas constant  $R=2 \text{ cal/mol}\cdot\text{K}$

1 atmosphere= $0.1 \text{ J/cm}^3$

1 cal= $4.2 \text{ J}$

melting point: water ( $0.00^\circ\text{C}$ )

heat of fusion: water ( $334 \times 10^3 \text{ J/kg}$ )

boiling point: water ( $100.0^\circ\text{C}$ )

heat of vaporization: water ( $2256 \times 10^3 \text{ J/kg}$ )

specific heat: water ( $4192 \text{ J/kg}\cdot\text{K}$ )

specific heat: copper ( $390 \text{ J/kg}\cdot\text{K}$ )

1. (27 points)

- a) A liter of ideal monatomic gas in a rigid cylinder at atmospheric pressure and  $0^\circ\text{C}$  is raised to  $100^\circ\text{C}$  by placing it in contact with an infinite reservoir at  $100^\circ\text{C}$ . What are the changes in entropy of the gas, the reservoir, and the universe in  $\text{J/K}$ ?
- b) Assuming that one wall of the cylinder is allowed to act like a piston, what is the change in entropy of the *universe* if the gas temperature is raised to  $100^\circ\text{C}$  by first compressing the gas with no contact with the reservoir so the temperature is raised to  $100^\circ\text{C}$  and then allowing the cylinder to expand isothermally back to 1 liter by placing the cylinder in contact with the reservoir?
- c) How much work is done to the gas during the compression process in part b), i.e., compress the gas without contact with the reservoir so the final state is at  $100^\circ\text{C}$ .

2. (25 points)

- a) A heavy copper pot of mass 2.0 kg (including the copper lid) is at a temperature of  $150^\circ\text{C}$ . You pour 0.10 kg of water at  $25^\circ\text{C}$  into the pot, then quickly close the lid of the pot so that no steam can escape. Find the final temperature of the pot and its contents, and determine the phase of the water. Assume that no heat is lost to the surroundings.
- b) The earth orbits the sun in an orbit we can assume to be circular at distance  $D$  from the sun's center, where  $D \gg r$ , the radius of the earth. The sun, a sphere of radius  $R$ , radiates as a black body at a temperature  $T_{\text{sun}}=6000 \text{ K}$  and subtends an arc of  $0.5^\circ$  as seen from the earth. What is the equilibrium temperature of the earth?

3. (48 points)

Consider a 1-dimensional Fermi gas of  $N$  non-interacting electrons of mass  $m$ , confined to a wire of large length  $L$ . Hint: don't forget spin.

- a) What is the number of states with momentum vector amplitude between  $k$  and  $k+dk$ ?
- b) What is the number of states with energy between  $E$  and  $E+dE$ ?
- c) What is the Fermi Energy of this system at  $T=0\text{K}$ ?
- d) What is the mean energy of the system at  $T=0\text{K}$ ?
- e) What is the mean energy of a classical ideal gas of  $N$  particles at  $T=0\text{K}$ ?
- f) What would the mean energy be for  $N$  bosons at  $T=0\text{K}$ ?

Comprehensive Exam: Classical Mechanics

March. 24, 1997: 11:30 AM-1:00 PM

1. a) A particle of mass  $m$  slides down an inclined plane of angle  $\theta$ . If the coefficient of friction for the plane is  $\mu$ , determine the particle's velocity and acceleration at time  $t$ , and the distance it travels assuming that it starts at the top at  $t=0$ .

b) The attractive force between a neutron and a proton is given by the Yukawa potential:

$V(r) = \frac{-g^2 e^{-\mu r}}{r}$ , where  $g$  and  $\mu$  are constants. Find the corresponding force and calculate the total energy and momentum assuming it carries out a circular motion of radius  $r$ .

2.

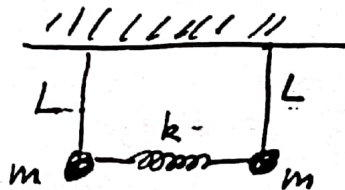

The above sketch describes two pendulum of length  $L$  connected by a spring of force constant  $k$ . Consider small amplitude motion in the plane and determine the normal modes of the system and their corresponding frequencies.

3. Consider infinitesimal motion of a rigid body so that there are two sets of axes, one fixed in space, another fixed in the body. If  $\vec{\omega}$  is the instantaneous angular velocity of the body, then show that the time rates of change of an arbitrary vector  $\vec{A}$  in the two systems are given by:

$$\left. \frac{\partial \vec{A}}{\partial t} \right|_{\text{space}} = \left. \frac{\partial \vec{A}}{\partial t} \right|_{\text{body}} + \vec{\omega} \times \vec{A}.$$